

Large Gas Spring Mount Option

90.30 Split Flange Mount

DADCO's new compact split flange mount uses the bottom groove for mounting and allows easy access for hose routing. The 90.30 mount can be used with DADCO's U, UK, UH and UX series 800, 1000, 1600 and 2600 models. For additional sizes, please contact DADCO.

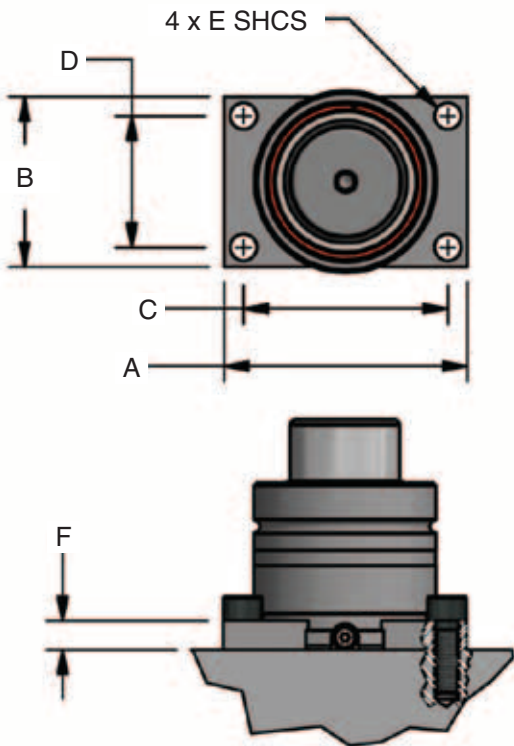

Part No.	Model Size			
90.30.____	00800	01000	01600	02600
Can Diameter	ø44.5mm	ø50mm	ø63mm	ø75mm
A	70.0 2.76	75.0 2.95	85.0 3.35	100.0 3.94
B	40.0 1.58	45.0 1.77	58.0 2.28	70.0 2.76
C	57.0 2.244	62.0 2.441	69.0 2.717	84.0 3.307
D	27.0 1.063	32.0 1.260	42.0 1.654	54.0 2.126
E	M8	M8	M10	M10
F	7.0 0.28	12.0 0.47	12.0 0.47	12.0 0.47

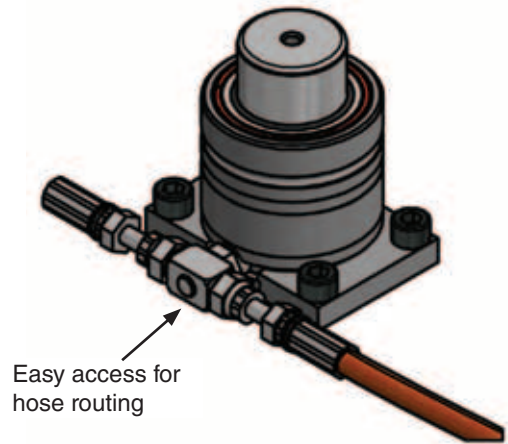

Mount Only Ordering Example: 90.30.02600

Cylinder with Mount Ordering Example:

