

SLN.300 Nitrogen Gas Lifter Repair Instructions

CAUTION: Always wear safety goggles when performing any maintenance work.

I. Exhausting Pressure



1. Remove the rod retainer screw from the bottom of the lifter using a 4 mm allen wrench.



2. When exhausting pressure, position the lifter horizontally with the port up and rod extended for safety.



3. Remove the M6 Port Plug, (90.607.110). Retain parts for use during reassembly.



4. Keeping face and hands clear of the port, use the Valve Bleed Tool, (90.360.4), or Port Servicing Tool, (90.320.8), to depress the Compact Valve, (90.260). Cover the port with a cloth to absorb discharge.



5. Stand the lifter upright. Make sure all of the gas pressure is exhausted, and that the Guide Rod will freely retract into the tube manually. If not, try depressing the valve again. If still unsuccessful **stop** and contact DADCO.

II. Port Maintenance



1. Pull the Guide Rod up by hand. If the valve appears damaged, is leaking pressure or sticking, proceed to step 2. Otherwise leave the valve undisturbed and proceed to "III. C-Ring Removal."



2. Remove the Compact Valve, (90.260), by unthreading it with the Port Servicing Tool, (90.320.8).

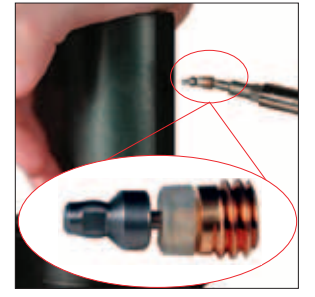

3. Thread a new Compact Valve, into the port until it fits snugly on the seat. Avoid over torquing the valve.

III. C-Ring Removal



1. Remove the two screws from the key plate using a 6 mm allen wrench.



2. Remove the three cartridge retaining set screws from the tube, by unthreading them with a 3 mm allen wrench.



3. Stand the lifter upright. Place a removal sleeve, (90.341.00800), longer than the stroke over the Guide Rod. Tap the sleeve until the Dust Cover, (90.246.10.01500), is loosened. Remove the Dust Cover and discard.

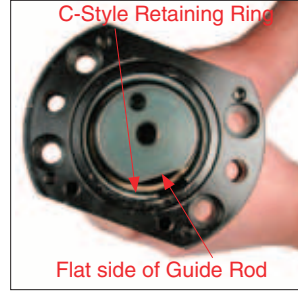

4. Repeating the removal sleeve and continue tapping until the Bearing is slightly below the retaining ring groove. Rotate the Guide Rod until the flat of the rod is aligned with the end of the C-Style Retaining Ring, (90.285A.01500).



5. Remove the C-Style Retaining Ring, using the C-Ring Removal Tool (90.355). Position the C-Ring Removal Tool at the flat of the Guide Rod and locate the tool under the end of the C-Style Retaining Ring.



6. Extract the c-ring by pushing the C-Ring Removal Tool toward the outside of the gas lifter. Remove the c-ring and retain for use during reassembly.



7. To remove the Guide Rod and Bearing Assembly thread a T-Handle (90.320.12) into the cylinder end. Pull the entire assembly out of the Tube Assembly. The lifter body can be held in a vise (with soft jaws) while pulling out the assembly.



8. Slide the Bearing Assembly off the Guide Rod and discard. Retain the rod for inspection and reuse.

V. Cleaning & Inspection



1. Lightly polish the Guide Rod surface with an emery cloth (600 grit). Inspect the finish for any scratches or gouges. If the Guide Rod is damaged it must be replaced.



2. Inspect the Tube Assembly for any damage. Lightly polish out any scratches at the mouth of the Tube Assembly for ease of assembly. If damage to the Tube Assembly is severe it must be replaced. Wash, clean and dry the inside thoroughly.



3. Inspect the Piston and Cushion for damage or wear. If the Piston or Cushion is damaged it must be replaced. SLN.300 Lifters manufactured prior to week 18 of 2007 (md1807) will have a previous style Piston and Piston Rider. **NOTE: The Piston, Piston Rider and Cushion included in the repair kit retrofit lifters manufactured prior to week 18 of 2007 (md1807).**

VI. Piston and Cushion Removal



1. Remove the Retaining Ring from the Piston using the Port Servicing Tool's, (90.302.8), small flat bit.



2. Slide the Piston off of the Guide Rod. **NOTE: If Piston shows signs of damage it must be replaced.**



3. Slide the Cushion off of the Guide Rod. **NOTE: If Cushion shows signs of damage it must be replaced.**



4. Remove the Rider from the Piston and inspect. Clean the Piston. Snap the new Rider onto the Piston, set aside for reassembly.

VII. Internal Rod Removal



1. Place a Removal Sleeve (90.340.00300) over the Internal Rod. Tap the sleeve until the housing is slightly below the retaining ring groove. The bore of the Guide Rod is designed to stop the cartridge in this position. **DO NOT force the cartridge down further into the Guide Rod.**



2. Remove the C-Style Retaining Ring, (90.285.3.0300), using a C-Ring Removal Tool, (90.355). Position the hooked end of the tool below the c-ring. For best results, locate the tool near either end of the c-ring.



3. Once the hooked end of the tool is firmly seated below the c-ring, begin pushing it toward the outside of the Guide Rod. The handles will close naturally, and the c-ring will be extracted as you complete this motion. For a detailed explanation of c-ring removal see bulletin B13113A.



4. To remove the Internal Rod and Cartridge Assembly, thread a T-Handle (90.320.1) into the end of the Internal Rod. Pull the entire assembly out of the Guide Rod. The Guide Rod can be held in a vise (with soft jaws) while pulling out the assembly.



5. Slide the cartridge off the Internal Rod and discard. Retain the Internal Rod for inspection and reuse.



6. Lightly polish the Internal Rod surface with an emery cloth (600 grit). Inspect the finish of the rod for any scratches or gouges. If the Internal Rod is damaged it must be replaced.



7. Inspect the Guide Rod for any damage, especially around the mouth. Lightly polish out any scratches at the mouth of the housing to avoid damaging seals during the reassembly process. If damage to the Guide Rod is severe, it must be replaced. Wash, clean and dry the inside thoroughly.

NOTE: Before starting the reassembly process, be sure the repair area is clean. It is imperative that the gas lifter be free of all contaminants upon reassembly. If this precaution is not taken it may lead to contamination and premature gas lifter failure.

VIII. Seal Kit Replacement and Reassembly



1. Position the new Cartridge Assembly over the Internal Rod. Make sure that the wiper end is facing up. While holding the cartridge, slide it vertically down the rod to the rod retainer. Be careful not to force the cartridge at an angle to avoid seal or bearing damage.



2. Lubricate the inside wall of the Guide Rod with all of the DADCO Assembly Oil.



3. Place the Internal Rod and cartridge into the Guide Rod. Position the top of the cartridge just below the retaining ring groove. The bore of the Guide Rod is designed to stop the cartridge in this position. **DO NOT force the cartridge down further into the Guide Rod.**



4. Insert the C-Style Retaining Ring, (90.285A.01500), in the retaining ring groove using a soft rubber mallet. **Be sure the c-ring is fully seated in the retaining ring groove.**



5. Install the Cushion onto the Guide Rod, then install the Piston onto the Guide Rod with Piston chamfer facing toward the cartridge.



6. Install the new Retaining Ring by pressing into place with the Port Servicing Tool's, (90.320.8), small flat bit. **The Retaining Ring must be completely seated in the square groove.**



7. Thread the T-Handle, (90.320.1) into the end of the Internal Rod. Pull up on the T-Handle until the top of the cartridge is completely past the c-ring. The rod must seat the cartridge assembly fully before charging. The cartridge assembly should be flush with the end of the cylinder. Make sure the Internal Rod is extended to its proper stroke length. (Depress the needle valve to facilitate full rod extension.)



8. Position the new Bearing over the Guide Rod. Make sure the bearing is in correct orientation, with the 45° chamfer side facing toward the Guide Rod. Slide the bearing down to the Piston.



9. Lubricate the inside wall of the Tube Assembly and Piston Rider with all of the DADCO assembly grease. Place the Guide Rod and Bearing Assembly into the Tube Assembly.



10. Place the removal sleeve, (90.341.00800), over the Guide Rod. Tap the sleeve until the Bearing is slightly below the retaining ring groove.



11. Install the rod retainer screw into the bottom of the lifter using a 4 mm allen wrench.



12. Insert the C-Style Retaining Ring, (90.285A.01500), in the retaining ring groove using a soft rubber mallet. **Be sure the C-Style Retaining Ring is fully seated in the retaining ring groove. NOTE: DADCO C-Ring Installation Tool, (90.350.01500), may be used if mount is removed.**



13. Thread the T-Handle, (90.320.12) into the end of the Guide Rod. Pull up on the T-Handle until the top of the Bearing is completely past the c-ring. The rod must seat the Bearing fully before charging. The Bearing should be flush with the end of the cylinder. **Make sure the Guide Rod is extended to its proper stroke length.**



14. Install the three cartridge retaining set screws into the tube using a 3 mm allen wrench. Do not over tighten.



15. Press the Guide Rod into the tube. Using a soft rubber mallet install the Dust Cover (90.246.10.01500).



16. Pull the Guide Rod up by hand. Install the key with two screws onto the Tube Assembly using a 6 mm allen wrench and a .005 inch shim.

Note: For best results, use the DADCO Charging Assembly which has a shut off valve and Quick Disconnect Adaptor at the end of the hose.

IX. Charging

Quick Disconnect Filling Method



1. Open the main valve on the nitrogen tank. Set the desired charging pressure on the regulator. DADCO recommends charging the lifter to the maximum charging pressure of 150 bar (2175 psi).



2. Thread the M6 end of the Quick Disconnect Filler Valve, (90.310.143), into the port of the gas lifter. Connect the female end of the charging assembly to the charging nipple. The DADCO Pressure Analyzer, (90.315.5), may also be used.



3. Slowly open the shut-off valve at the end of the charging hose. Charge to low pressure first, then proceed to charge to full desired pressure. After the lifter has been charged to the desired pressure, CLOSE THE HOSE SHUT-OFF VALVE and disconnect the charging assembly from the charging nipple. Remove the Quick Disconnect Filler Valve.



4. Check for leaks around the valve compartment by using mineral oil or water to test for leaks.

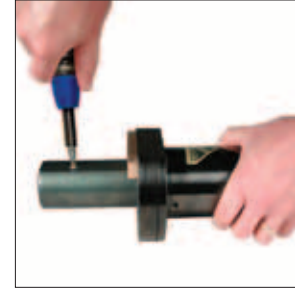

5. Securely thread the Port Plug, (90.607.110), into the port.

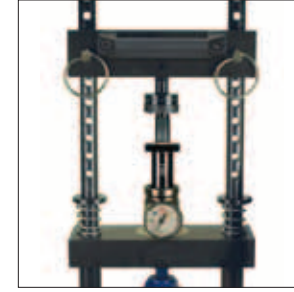

6. Verify the pressure in the SLN.300 Nitrogen Gas Lifter with the SLN.300 Load Cell (90.301.00300) using a DADCO Mini Test Stand, (90.305.2).

X. Adjusting Gas Lifter Pressure



1. To increase the lifter pressure, thread the Quick Disconnect Filler Valve, (90.310.143), into the port, set the regulator to the desired pressure and fill. The DADCO Pressure Analyzer (90.315.5) may also be used to adjust pressure.



2. To decrease the gas lifter pressure, depress the valve stem using a DADCO Valve Bleed Tool, (90.360.4). The DADCO Pressure Analyzer (90.315.5) may also be used to adjust pressure.

Repair Tools

C-Ring Removal Tool • 90.355

To remove the C-Style Retaining Ring from the SLN Guide Rod safely in a single controlled motion. For more information, request bulletin B13113A.



Removal Sleeves • 90.340.00300 • 90.341.00800

To position the cartridge or bearing below the c-ring groove when assembling or disassembling the SLN.300 Nitrogen Gas Lifter.



Valve Bleed Tool • 90.360.4

Use the DADCO Valve Bleed Tool to slowly discharge the SLN.300 Nitrogen Gas Lifter to the desired pressure.



T-Handles: 90.320.1: M6 thread 90.320.12: M12 thread

To remove the Internal Rod and Cartridge Assembly or the Guide Rod and Bearing Assembly during disassembly. Also used for correct positioning during reassembly.



Port Servicing Tool • 90.320.8

To perform all necessary servicing to the valve compartment. For more information, request bulletin B05110A.



Quick Disconnect Filler Valve • 90.310.143

Use the DADCO Quick Disconnect Filler Valve to charge the SLN.300 Nitrogen Gas Lifter. For more information contact DADCO.



SLN.300 Load Cell • 90.301.00300

When used with a Mini Test Stand, the Load Cell gives precise measurement of the charging pressure for the SLN.300 Nitrogen Gas Lifter.



Mini Test Stand • 90.305.2

Use the Mini Test Stand in conjunction with the SLN.300 Load Cell for precise measurement of force on contact. For more information, request bulletin B08108B.



DADCO Pressure Analyzer • 90.315.5

Use the DADCO Pressure Analyzer to easily charge, discharge, and gauge the pressure in the SLN.300 Nitrogen Gas Lifter. For more information, request bulletin B01133E.



Quick Disconnect Charging Assembly • 90.310.040

Use the DADCO Quick Disconnect Charging Assembly with the Filler Valve or Pressure Analyzer to charge the SLN.300 Nitrogen Gas Lifter. For more information contact DADCO.



Parts List

Note: The SLN.300 Nitrogen Gas Lifter is permanently marked with model number, serial number and repair kit number. Please refer to these when ordering replacement parts.

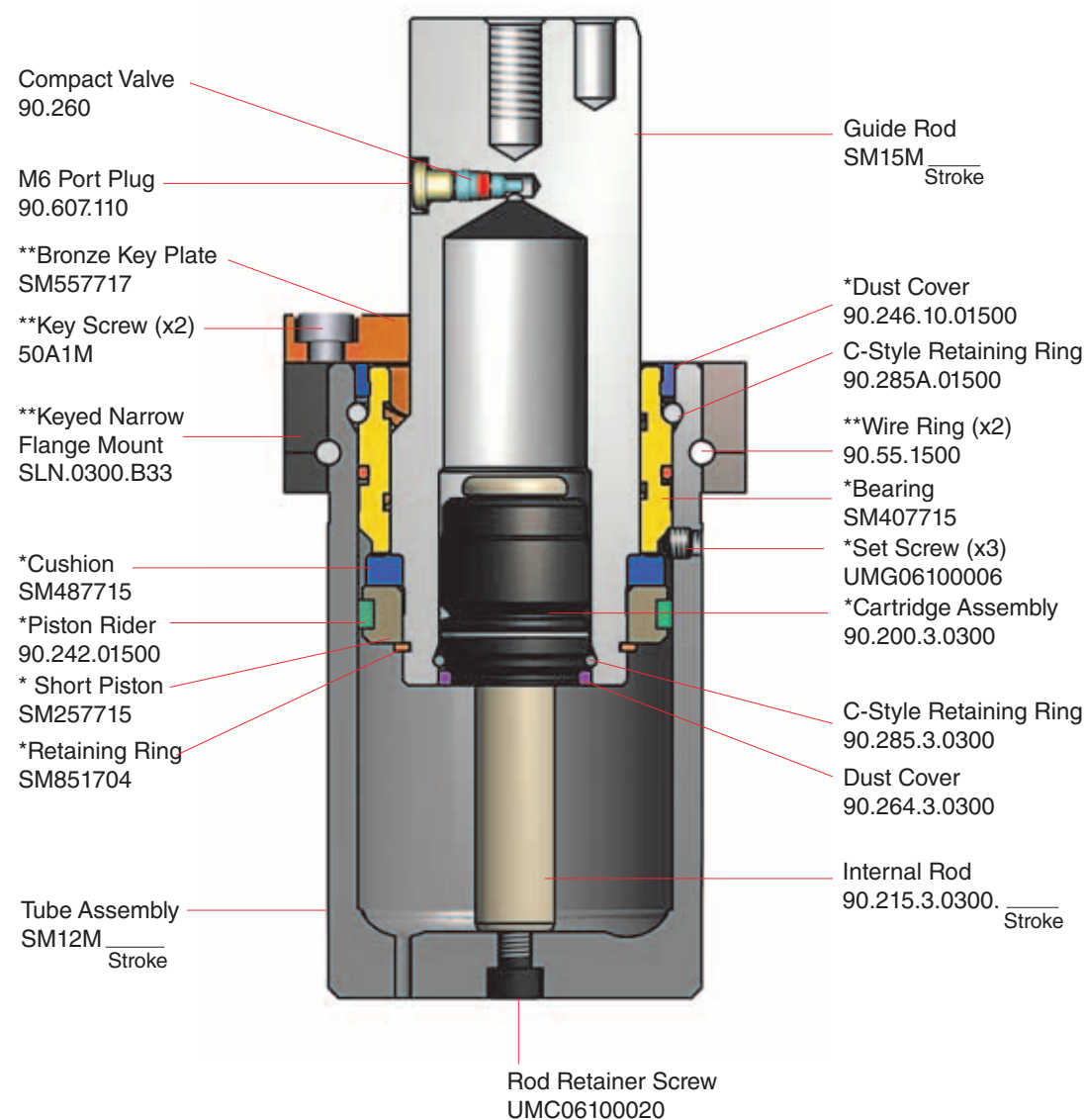

Bulletin No. B04110B

Comprehensive Guide

This service manual is a step-by-step maintenance guide for DADCO's SLN.300 Non-Rotating Nitrogen Gas Lifter.

Proper repair requires careful examination of all component parts and replacement of any that are worn or damaged. All DADCO replacement parts are available from factory stock.

After reviewing this maintenance guide, if you require any additional training or have any questions please contact DADCO for assistance.



Nitrogen Gas Lifter Maintenance Instructions SLN.300



Note: The SLN.300 Nitrogen Gas Lifter is permanently marked with model number, serial number and repair kit number. Please refer to these when ordering replacement parts.

*The SLN.300 Repair Kit (SLN.RK.300) includes a dust cover, bearing, cartridge assembly, short piston, piston rider, retaining ring, cushion, set screws, bottle of assembly oil, assembly grease and a maintenance manual. This repair kit can be used for the maintenance of all SLN.300 lifters. If you require assistance or have any questions please contact DADCO for assistance.

**SLN.0300.B33 Keyed Narrow Flange Mount includes mount upper, mount lower, bronze key plate, key screws and wire rings.

All DADCO bulletins and catalogs are available for download from our web site, www.dadco.net.

©DADCO, Inc. 2018 • All Rights Reserved

DADCO

43850 Plymouth Oaks Blvd.
Plymouth, Michigan USA 48170
734.207.1100 • 800.323.2687
Toll Free: 1.800.DADCO.USA
Fax: 734.207.2222
www.dadco.net