

SLN.300 Maintenance Instructions

Use in conjunction with DADCO's SLN.300 Maintenance Instructions (B04110)

DADCO's SLN.RK.300 repair kit can be used to repair all SLN.300 Non-Rotating Nitrogen Gas Lifters. SLN.300 Lifters manufactured after week 18 of 2007 (*md1807*) will have a new Piston, Piston Rider and Cushion construction. The Piston, Piston Rider and Cushion retrofit into SLN.300 lifters manufactured before week 18 of 2007 (*md1807*). Please follow the instructions below in conjunction with the SLN.300 Maintenance Instructions (B04110) for proper inspection, removal and installation of the Piston, Piston Rider and Cushion. After reviewing this maintenance guide, if you require any additional training or have any questions please contact DADCO for assistance.

CAUTION: Always wear safety goggles when performing any maintenance work.

Continued from DADCO's SLN.300 Maintenance Instructions

V. Cleaning & Inspection — VI. Piston and Cushion Removal



3A. Inspect the Piston and Cushion for damage or wear. If the Piston or Cushion is damaged it must be replaced. SLN.300 Lifters manufactured after week 18 of 2007 (*md1807*) will have a new Piston, Piston Rider and Cushion. *NOTE: The Piston, Piston Rider and Cushion retrofit lifters manufactured before week 18 of 2007 (md1807).*



1. Remove the Retaining Ring from the Piston using the Port Servicing Tool's small flat bit.



2. Slide the Piston off the Guide Rod. *NOTE: If Piston shows signs of damage it must be replaced.*



3. Slide the Cushion off the Guide Rod. *NOTE: If Cushion shows signs of damage it must be replaced.*

Continued from DADCO's SLN.300 Maintenance Instructions

VIII. Seal Kit Replacement and Reassembly



4. Remove the Rider from the Piston and inspect. Clean the Piston. Snap the new Rider onto the Piston, set aside for reassembly. **Return to DADCO's SLN.300 Maintenance Bulletin VII. Internal Rod Removal.**



5A. Install the Cushion onto the Guide Rod.



5B. Install the Piston onto the Guide Rod with Piston chamfer facing toward the cartridge.



6. Install the new Retaining Ring by pressing into place with the Port Servicing Tool's small flat bit. The Retaining Ring must be completely seated in the square groove. **Return to DADCO's SLN.300 Maintenance Bulletin VIII. Seal Kit Replacement and Reassembly, step 7.**

Parts List

Note: The SLN.300 Nitrogen Gas Lifter is permanently marked with model number, serial number and repair kit number. Please refer to these when ordering replacement parts.

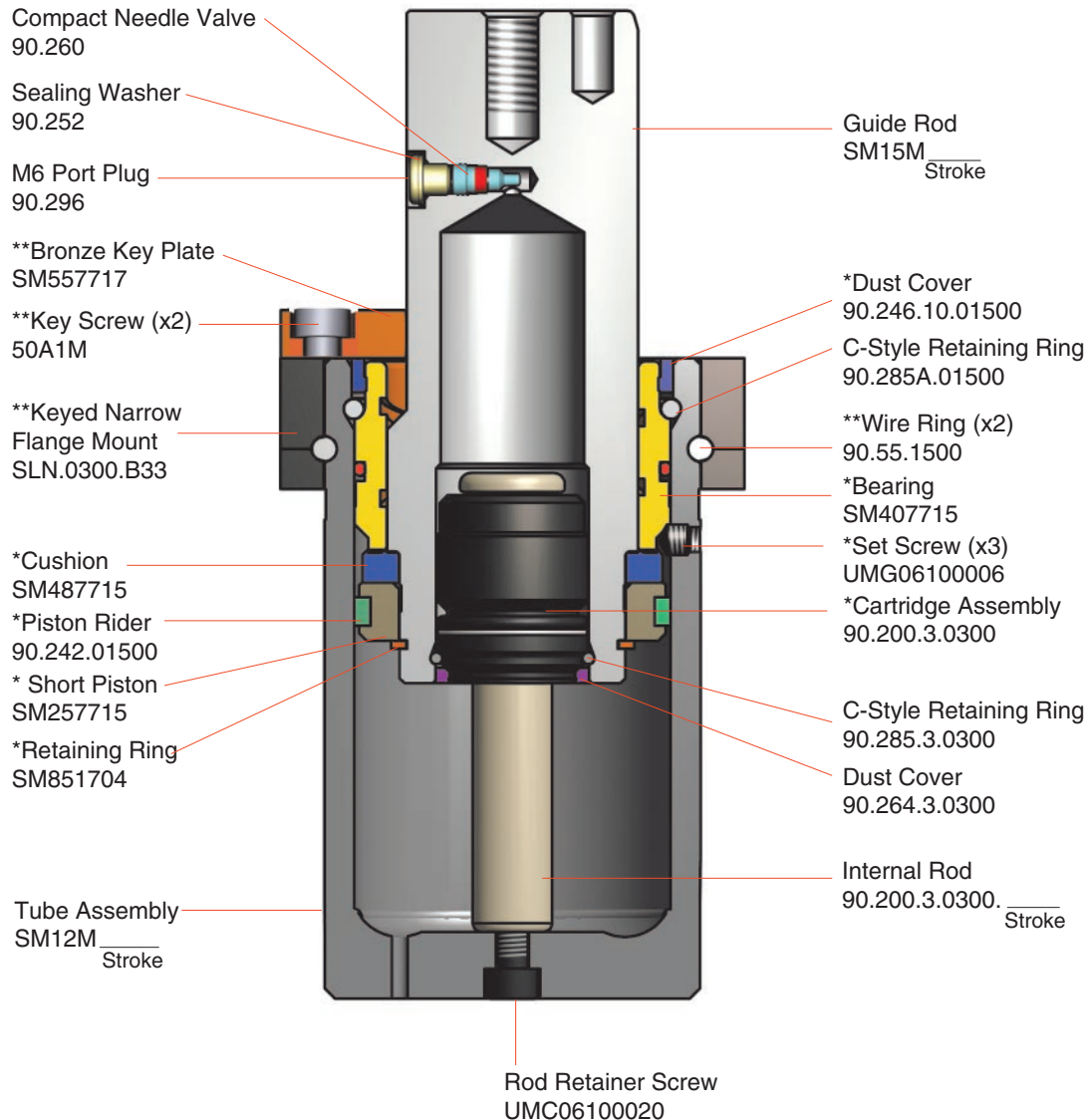

*The SLN.300 Repair Kit (*SLN.RK.300*) includes a dust cover, bearing, cartridge assembly, short piston, piston rider, retaining ring, cushion, set screws, bottle of assembly oil, assembly grease and a maintenance manual. This repair kit can be used for the maintenance of all SLN.300 lifters. If you require assistance or have any questions please contact DADCO for assistance.

**SLN.0300.B33 Keyed Narrow Flange Mount includes mount upper, mount lower, bronze key plate, key screws and wire rings.