

Guide Retainer Sets

GRS.50.HD.R

DADCO offers the GRS.50.HD.R to meet the General Motors GMNA standard specifications (N90.80.915) for Progressive Dies Retrofit ø50 HD Guide/Keeper.

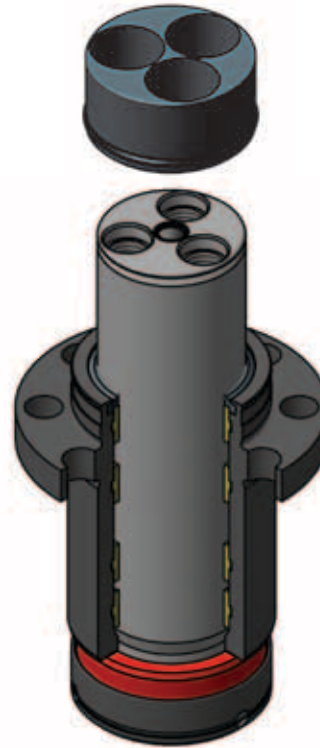
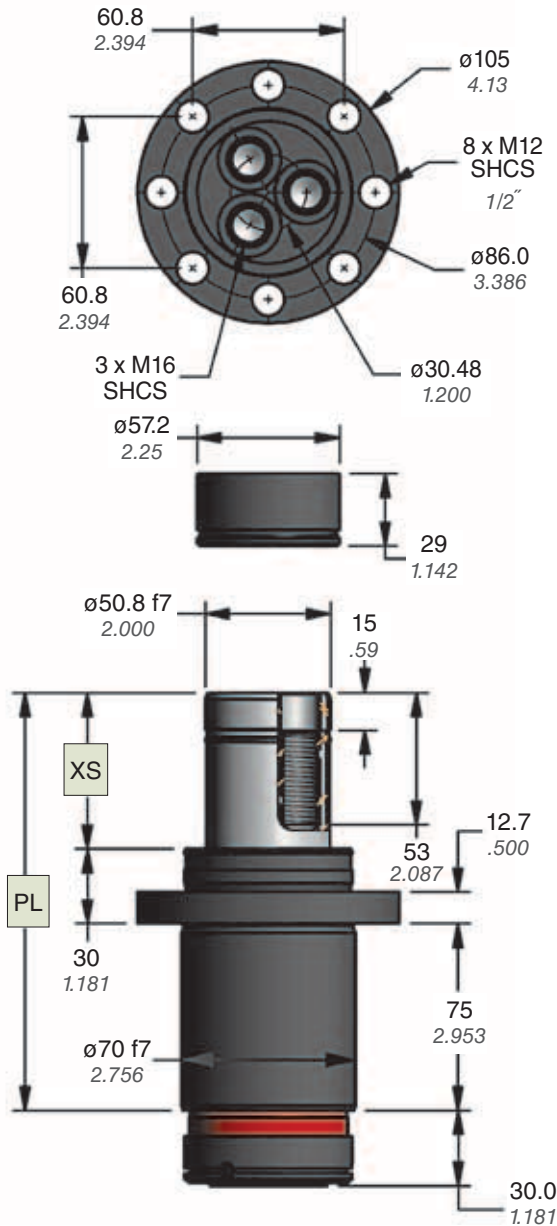

GMGDS Code	Pin Length Code	XS		PL		Max Travel	
		mm	inch	mm	inch	mm	inch
M-1943-162	0570	57.0	2.244	162.0	6.378	32.0	1.260
M-1943-172	0670	67.0	2.638	172.0	6.772	42.0	1.654
M-1943-182	0770	77.0	3.031	182.0	7.165	52.0	2.047
M-1943-192	0870	87.0	3.425	192.0	7.559	62.0	2.441
M-1943-202	0970	97.0	3.819	202.0	7.953	72.0	2.835
M-1943-212	1070	107.0	4.212	212.0	8.346	82.0	3.228
M-1943-222	1170	117.0	4.606	222.0	8.740	92.0	3.622
M-1943-232	1270	127.0	5.000	232.0	9.134	102.0	4.016
M-1943-242	1370	137.0	5.394	242.0	9.527	112.0	4.409

Ordering Example:

GRS. 50. HD. R. 0570. FH .AC

Series: Guide Retainer Set

Guide Rod Diameter: ø50

Guide Rod Type: Heavy Duty

Guide Rod Option: R = Retrofit

Plate Adapter

Guide Retainer Mount Option: FH = Flange Mount

Pin Extension Length: Use order code listed above.
Example: 0570 = 570 mm (XS Dimension)

Replacement Part Ordering Information:



Guide Rod:
GRS.50HD.R.0570.RO



Guide Retainer:
GRS.50HD



Plate Adapter:
GRS.50.AC

Repair Kit:

GRS.50HD.RK
Includes bushings, rod wiper, dampener and a maintenance manual.

B16116

Technical Data

Maximum Attachment Capacity

The guidelines below show attachment limits per GRS based on press ram velocity. For increased capacity, install additional Guide Retainer Sets.

Velocity Estimate (m/sec)		0.50	0.60	0.65	0.75	0.80	0.90	0.95	1.00	1.05	1.10
Per GRS	max (lb.)	1058	735	626	470	413	327	293	265	240	219
	max (kg)	480	333	284	213	188	148	133	120	109	99
Pad Mass		GRS.50.HD.R Quantity									
lb.	kg										
250	113	2	2	2	2	2	2	2	2	3	3
500	227	2	2	2	3	3	3	3	3	4	4
750	340	2	3	3	3	3	4	4	4	5	5
1000	454	2	3	3	4	4	5	5	5	6	6
1250	567	3	3	3	4	5	5	6	6	7	7
1500	680	3	4	4	5	5	6	7	7	8	8
1750	794	3	4	4	5	6	7	7	8		
2000	907	3	4	5	6	6	8	8			
2250	1021	4	5	5	6	7	8				
2500	1134	4	5	5	7	8					

Pocket and Clearance Dimensions

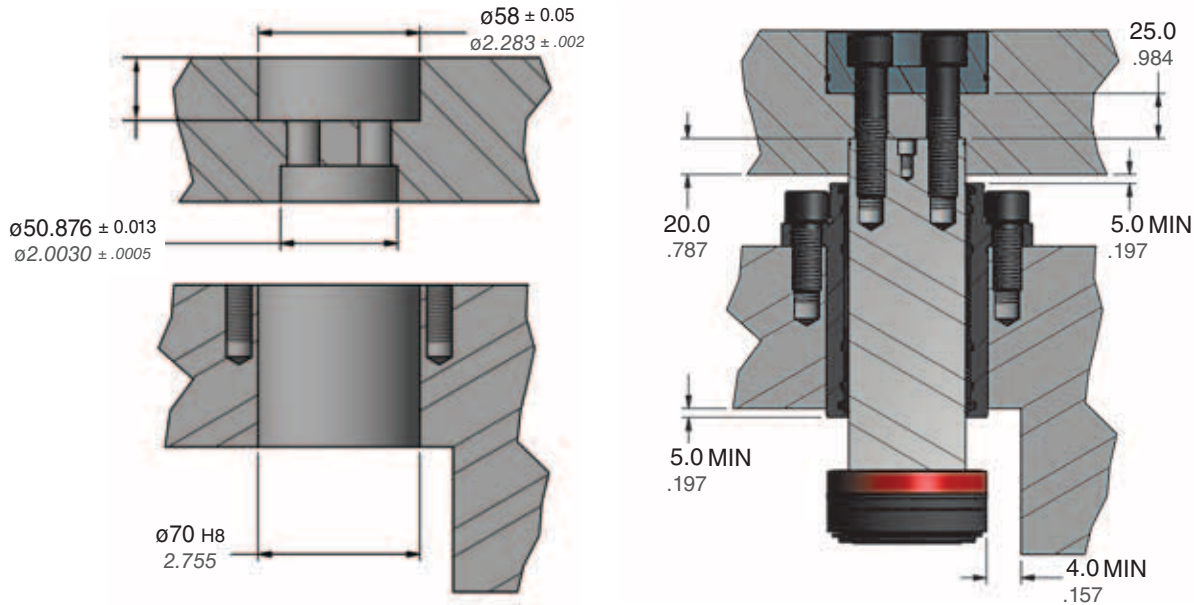

Pin Spacing

Deceleration of the pad may cause pad flexing to occur. Add additional GRS.50.HD.R to the center to prevent sideload from inertial deflection at end of stroke travel. Lighter pads may result in a flexible structure requiring center support. Heavier pads will require additional GRS to distribute the weight according to the shape and die steel attachments.

