

# Nitrogen Gas Stock Lifter

## E.16

DADCO's E.16 Nitrogen Gas Stock Lifter matches the European VDI-BAK standard and the Ford WDX35-70 standard.

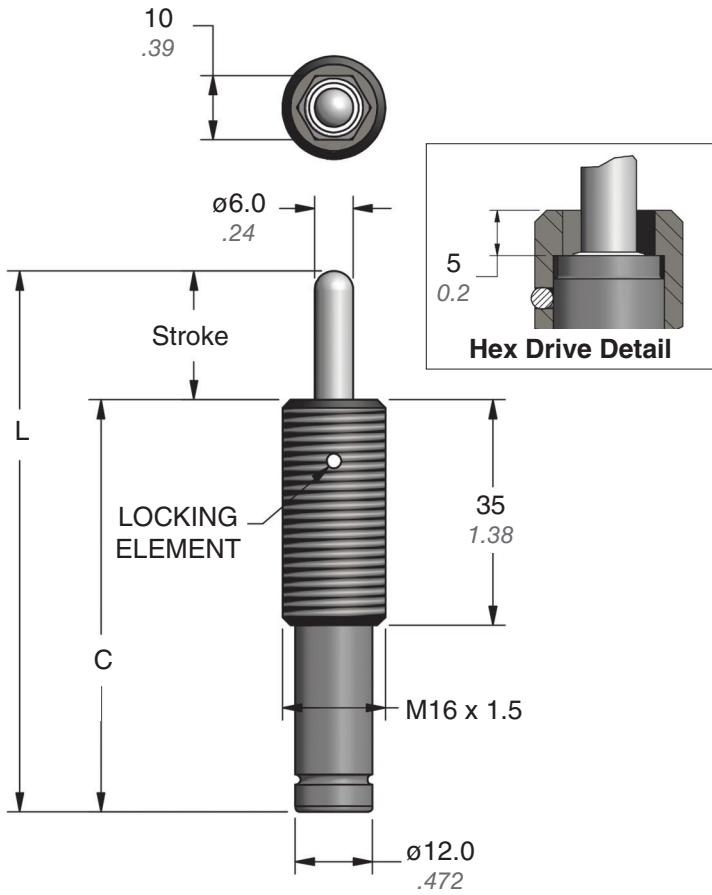

**Jam Nut**  
SL-16-JN

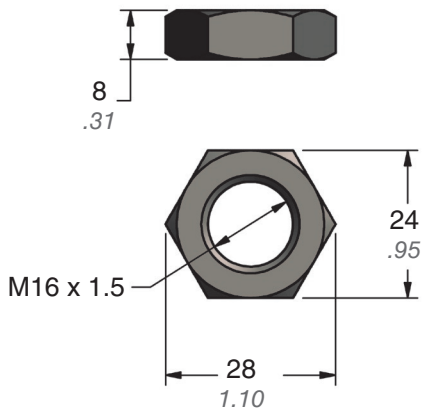

Part No.	Stroke mm <i>in</i>	C	L
E.16.020	20 .79	64 2.52	84 3.307
E.16.050	50 1.97	94 3.70	144 5.669
E.16.080	80 3.15	127 5.00	207 8.150

Pressure		Force on Contact	
Bar	<i>psi</i>	N	<i>lb.-f</i>
20	290	57	13
40	580	113	25
75	1088	212	48
150	2176	424	95
180	2611	509	114

**Installation and Removal Tool**  
RT-16-F

Ratcheting tool with internal hex drive for easy installation and removal of the E.16.



### Ordering Example:

**E.16.020. 150**

**Part Number**

Includes Series, Model, and Stroke Length

**Charging Pressure**

Specify pressure: 20-180 bar (290 *psi* – 2611 *psi*).  
When not specified, default is 150 bar.

## E.16 Operating and Technical Specifications

### Operating Specifications

Charging Medium:	Nitrogen Gas
Maximum Charging Pressure:	180 bar (2611 psi)
Operating Temperature:	20°F – 160°F (-6°C – 71°C)
Maximum Speed:	35 m/min (23 in/sec)

- DO NOT exceed 90% of stroke
- Design adequate safety so lifter is not over stroked

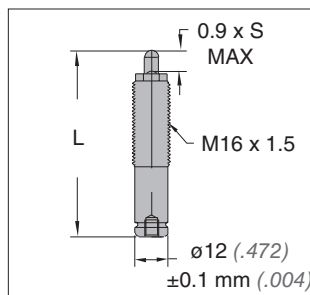

Basic dimensions

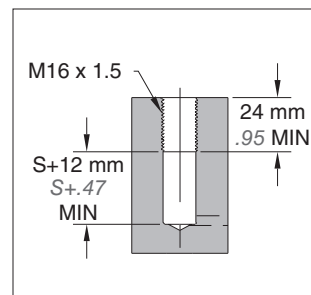

Pocket installation parameters.

### Installation Recommendations

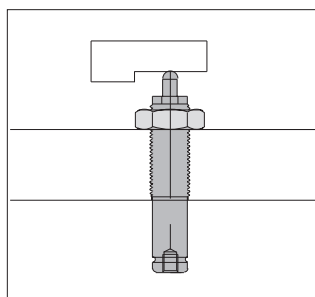

Strike surface should be hardened when possible. Rod end should locate freely.

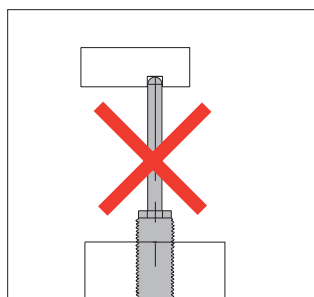

Do not constrain the rod end.

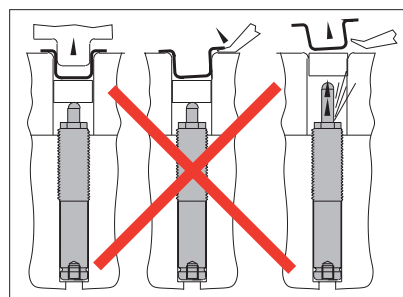

Jammed parts are dangerous, determine the cause and repair it before production continues. Failure to do so will cause damage to the lifter.

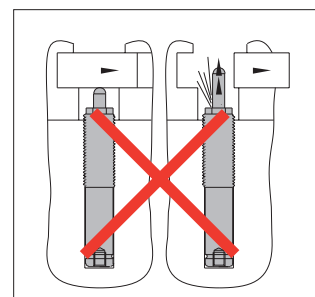

Sudden release will cause stock lifter to exhaust. Restricting rod travel by preloading will help prevent lifter damage.

### Charging and Discharging the E.16 Nitrogen Lifter

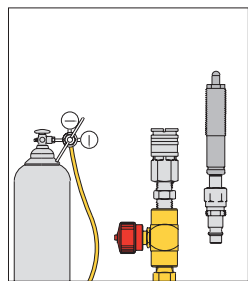

- When filling the Nitrogen Stock Lifter, initially fill with low pressure (< 6 bar / 80 psi) to extend the rod fully; then fill to desired pressure. Hold the spring vertically at all times during filling.
- The charging pressure range for the E.16 is 20 - 180 bar (290 psi – 2611 psi).
- **All stock lifters should be inspected for damage before charging. If damage is noted, discharge and discard the lifter.**
- **Always wear safety goggles and use extreme care when handling a stock lifter.**
- Be sure to discharge all pressure before disposing of lifter.

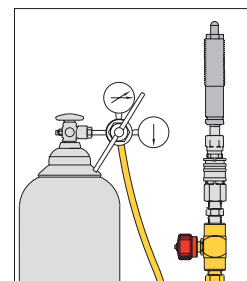

#### Quick Disconnect Charging Nipple – CN-4

Use the DADCO Quick Disconnect Charging Nipple to charge the E.16 nitrogen stock lifter. For more information, contact DADCO.



#### Valve Bleed Tool – 90.360.4

Use the DADCO Valve Bleed Tool to discharge the E.16 nitrogen stock lifter through the adjustable valve in the base.



To see DADCO's full line of accessories visit [www.dadco.net](http://www.dadco.net)

# DADCO®

43850 Plymouth Oaks Blvd • Plymouth, MI • 48170 • USA  
734.207.1100 • fax 734.207.2222 • [www.dadco.net](http://www.dadco.net)