

CAUTION: Always wear safety goggles when performing any maintenance work.

I. Micro 90™ Gas Spring Replacement

CAUTION!

Do not remove rear head if the rod is stuck in the down position. If the rod cannot be pulled up, the **Micro 90®** gas spring inside may be under pressure. Contact DADCO for assistance.



1. Wrap the SLN.090 cylinder body in a soft cloth. Clamp the SLN.090 face down in a vise so that the cylinder is secured. Remove the Rear Head, (SA107770), using the Rear Head Removal Tool Kit, (SLN.HR.090), and a wrench.



2. Remove the **Micro 90®** gas spring. If replacing the **Micro 90®** gas spring only, proceed to step 3. To continue maintenance of the SLN.090 with replacement parts from the repair kit, proceed to "II. Rod Key Removal" step 1.



3. To verify **Micro 90®** gas spring force before installation, refer to the Micro Load Cell Bulletin #B07108. Lightly oil the body of the **Micro 90®** gas spring and install it into the Tube. Add 2-3 drops of serviceable threadlocker to the threads of the rear head. Replace the rear head. Tighten using the Rear Head Removal Tool Kit, (SLN.HR.090), and a wrench to **180 lb-in / 20 N-m**.



See the Parts List drawing on the reverse side for replacement part information.

CAUTION! The **Micro 90®** gas spring inside is preloaded 1 mm.

II. Rod Key Removal



1. Remove the two screws from the bottom of the mount using a 2.5 mm allen wrench.



2. Slide the Upper Mount, (SA557770), off the Tube Assembly. The two Rod Keys are located in the Upper Mount.



3. Remove the two Rod Keys, (SA857770), from the Upper Mount, (SA557770), and inspect for wear. If the keys show signs of wear on only one side they may be turned 180 degrees and reused. If they show signs of wear on both sides, they must be replaced.

III. Bearing Removal



1. Slide the Lower Mount, (SA557771), off the Tube Assembly.



2. Pull the Guide Rod out of the Tube Assembly.



3. Slide the Bearing, (SA407770), off the Guide Rod and discard. Retain the rod for inspection and reuse.

NOTE: Before starting the reassembly process, be sure the repair area is clean. It is imperative that the gas lifter be free of all contaminants upon reassembly. If this precaution is not taken it may lead to contamination and premature gas lifter failure.

IV. Piston Rider Removal

100-125 mm stroke only



1. Remove the Piston Rider, (SA411661), from the Piston and discard. If repairing a 25-80 mm stroke cylinder, proceed to "V. Cleaning & Inspection," step 1.



2. Remove the two halves of the Piston, (SA257770). Clean and inspect. If the Piston is damaged it must be replaced. Note the proper orientation of the piston halves for reassembly.

V. Cleaning & Inspection



1. Clean the Guide Rod surface and inspect for deformation in the retaining groove area. If the Guide Rod is damaged it must be replaced.



2. Inspect the Tube Assembly for any damage, especially around the mouth of the Tube. Lightly polish out any scratches. If damage to the tube is severe it must be replaced. Wash, clean and dry the inside thoroughly.

VI. Reassembly



1. Install the Bearing, (SA407770), into the Tube. Make sure the Bearing is positioned correctly, with the chamfered side facing the Tube Assembly.



2. Install the Lower Mount, (SA557771), and Upper Mount, (SA557770), with Rod Keys onto the Tube Assembly. Install the two mount screws into the Lower Mount with a 2.5 mm allen wrench to 36 lb-in / 4 N-m. If repairing a 25-80 mm stroke cylinder, proceed to step 4.

VI. Reassembly (Continued)

100-125 mm stroke only



3. Carefully install the two Piston halves, (SA257770), onto the Guide Rod. Make sure the Piston is in correct orientation with the narrow flange toward the open end of the rod.



4. Snap the new Piston Rider, (SA411661), onto the Piston. Be careful not to deform the Piston Rider.



5. Lightly coat the inside of the Tube Assembly and Piston Rider with the DADCO assembly grease included in the repair kit.



6. Place the Guide Rod into the Tube Assembly. Make sure the Guide Rod is properly aligned to the Rod Keys.



7. To verify **Micro 90®** gas spring force before installation, refer to the Micro Load cell Bulletin #B07108. Clamp the Tube Assembly in a vise so the tube is secured. Lightly oil the body of the **Micro 90®** gas spring and install it into the Tube Assembly.



8. Add 2-3 drops of serviceable threadlocker to the threads of the rear head. Replace the Rear Head. Tighten using the Rear Head Removal Tool Kit, (SLN.HR.090), and a wrench to **180 lb-in / 20 N-m**.

SLN.090 Parts List

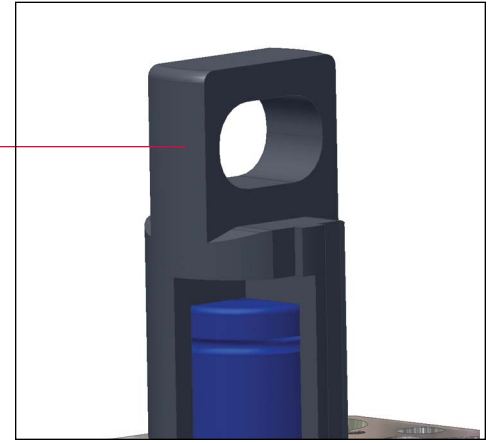
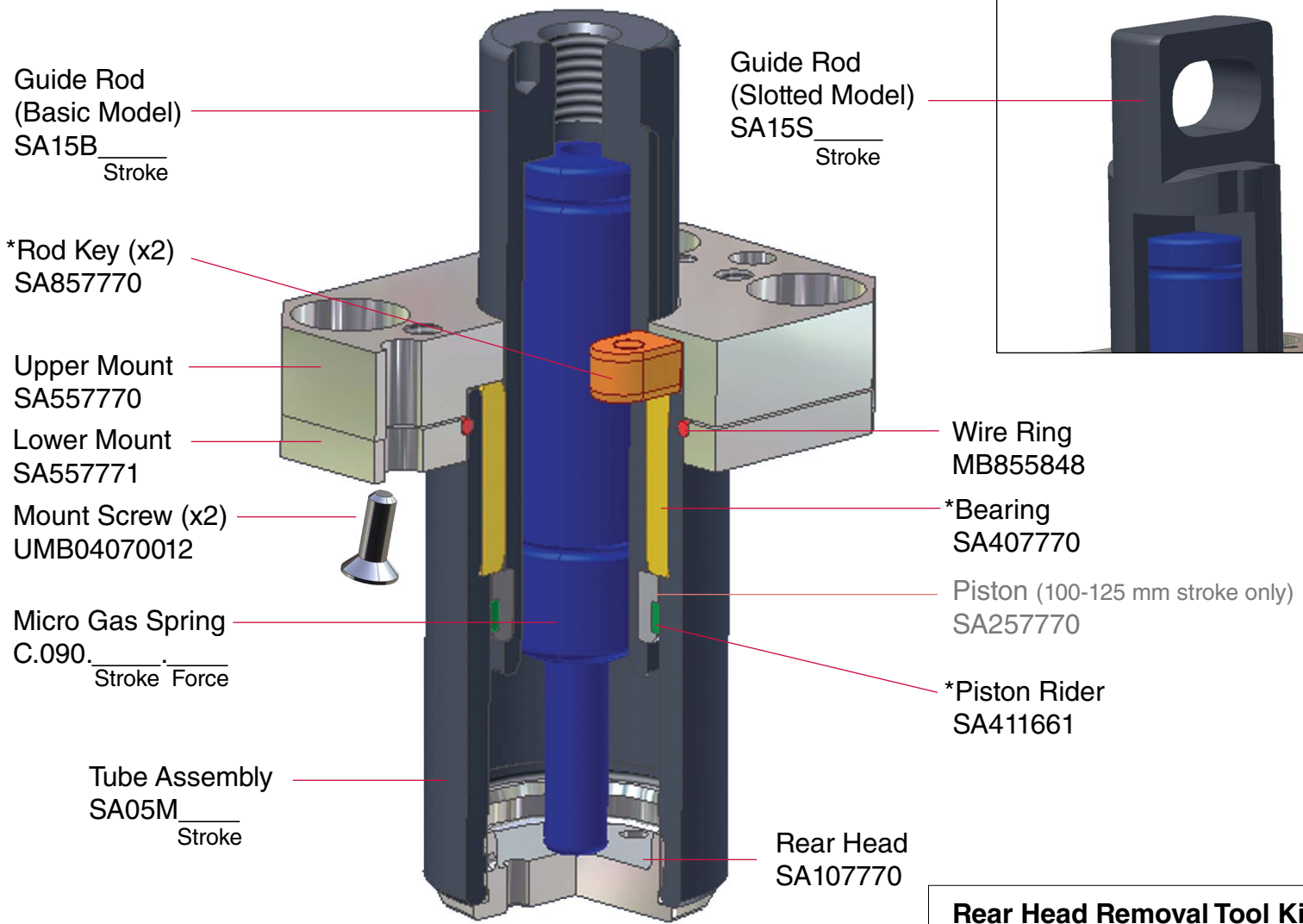

***SLN.090 Repair Kit**
SLN.RK.090

Repair kit includes bearing, piston rider, rod keys (2), assembly grease, threadlocker capsule and a maintenance manual.

Valve Bleed Tool
90.360.4

Use the DADCO Valve Bleed Tool to slowly discharge the **Micro 90**[®] gas spring to the desired pressure.



Rear Head Removal Tool Kit
SLN.HR.090

To remove the rear head from the SLN.090 Micro Nitrogen Gas Lifter when replacing the **Micro 90**[®] gas spring.
Max. Torque = 180 lb_f-in / 20 N·m



Bulletin No. B05107B

Quick and Easy Repair!

The SLN.090 Micro Nitrogen Gas Lifter is designed with DADCO's **Micro 90**[®] gas spring inverted in the guide rod for adjustable lifting force and easy repair. The **Micro 90**[®] may be replaced in just three simple steps!

A repair kit including bearing, piston rider and rod keys, provides replacement parts needed to maintain the lifter. DADCO recommends all replacement parts provided in the repair kit be installed at the same time. Replacement **Micro 90**[®] gas springs are sold separately.

Comprehensive Guide

This service manual is a step-by-step maintenance guide for DADCO's SLN.090 Micro Nitrogen Gas Lifter. Instructions in this guide apply to both the SLN.090.B (Basic Model) and SLN.090.S (Slotted Model). Repair instruction pictures feature the SLN.090.B (Basic Model).

Proper repair requires careful examination of all component parts and replacement of any that are worn or damaged. All DADCO replacement parts are available from factory stock.

After reviewing this maintenance guide, if you require any additional training or have any questions please contact DADCO for assistance.

Note: The SLN.090 Micro Nitrogen Gas Lifter is permanently marked with model number, serial number, gas spring part number and repair kit number. Please refer to these when ordering replacement parts.

All DADCO bulletins and catalogs are available for download from our web site, www.dadco.net.



Micro Nitrogen Gas Lifter Maintenance Instructions
SLN.090

