

DAPCO®

Nitrogen Gas Spring Lifters

SL Series



*Lifters for Single-Point, Multi-Point and
Rail Lift Applications*

Introduction

DADCO®

The global leader in nitrogen gas spring technology

DADCO produces top quality products at competitive prices and provides a superior level of customer service. Founded in 1958, DADCO is the highest volume producer of gas springs for press tools. DADCO's products are widely approved and used in global operations for many industries including metal stamping, automotive, and plastic injection molding.

SL Series

Save design, build, and installation time with DADCO's all-in-one approach to guided nitrogen lifters. Available in a full variety of models, including non-rotating and cushioned versions, DADCO's lifters are ideal for progressive dies.



High Quality Construction

To ensure their exceptionally long service life, DADCO's SL Series of Nitrogen Gas Lifters have high quality construction features.

DADCO's SLN.300, SLC.500 and SLC.800 lifters provide extended guide rod composite bushings that provide superior guidance and increase stability. All of the lifters have reliable lifting force that is provided by proven DADCO Nitrogen Gas Spring technology.



Non-Rotating and Two Post Lifters

The SLN.090, SLN.180, SL2.090, SL2.180 and SL2.300 utilize DADCO's popular Micro Series and Mini Series Nitrogen Gas Springs for their lifting force. Both gas spring series are backed by DADCO's exclusive written Guarantees and are easily adjusted or replaced in the field. Contact DADCO for more information.

Customer Satisfaction

DADCO's motto is "Whatever It Takes To Satisfy Our Customers." DADCO will assist in any way possible to ensure that customers are completely satisfied. DADCO's salespeople and distributors are solution-oriented, product-knowledgeable, and eager to assist customers. DADCO's engineers are available to help customers with specific applications.

Warranty

DADCO warrants its SL Series of Nitrogen Gas Spring Lifters to be free from defects in workmanship or materials for a period of one year from date of manufacture.

CAD Templates On-line

DADCO's entire product line is available on-line in solid models and 2D CAD formats. For more information, visit our website, www.dadco.net, or contact DADCO.

Rapid Delivery

DADCO's modern 13,150 m² main production facility as well as satellite facilities permit the fastest deliveries in the industry. Products are available both directly and through a network of trained distributors providing worldwide support.

Model	Can Diameter (mm / inch)		Max Force On-Contact (daN / lb.)		Page
SLN.090	38	1.496	89	200	5
SLN.180	50	1.968	200	450	6
SLN.300	75	2.953	302	678	7
SLC.500	50	1.96	220	487	12
SLC.800	75	2.95	712	1578	12
Model	Rail Width		Max Force On-Contact		Page
SL2.090	160	6.30	89	200	9
SL2.180	180	7.09	200	450	10
SL2.300	180	7.09	302	678	11
Model	Can Diameter (mm / inch)		Max Force On-Contact (daN / lb.)		Page
SLN.180.FA / FB	50	1.968	149	337	14

Flange Strippers

The SLN.180.FA / FB Flange Model Nitrogen Gas Lifter is the newest addition to the SL Series. This solution-based product is used to strip the part from the die in forming applications. For other lifter solutions contact DADCO.

Product Overview

DADCO offers a variety of Nitrogen Gas Spring Lifters for different applications. Refer to the information below to determine which lifter best suits your needs. The following pages detail the different models including technical installation data. Contact DADCO for more information or specific application questions.

Non-Rotating Nitrogen Gas Lifters – SLN.090, SLN.180 and SLN.300

- Non-Rotating, All-In-One Lifter
- Built-in Guidance
- Single, multi-point or rail lift applications
- Force provided by Micro/Mini Series Nitrogen Gas Springs
- Ideal for progressive stamping dies



SLN basic model lifter in a single-point application

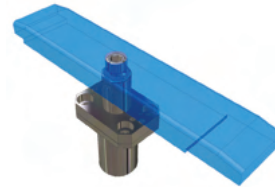

Two SLN slotted model lifters in a rail application

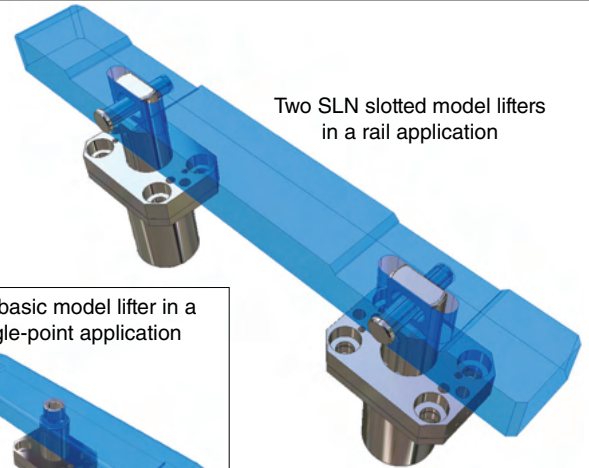

Nitrogen Gas Spring Rail Lifters – SLC.500 and SLC.800

- Cushioned Rail Lift
- Eliminate guide and shock absorbing elements
- Longer rod guide assures stable lifting
- Decelerate load for improved part handling
- Linked units provide uniform lifting force
- Ideal for progressive die lifter rail, work holding and balancing applications

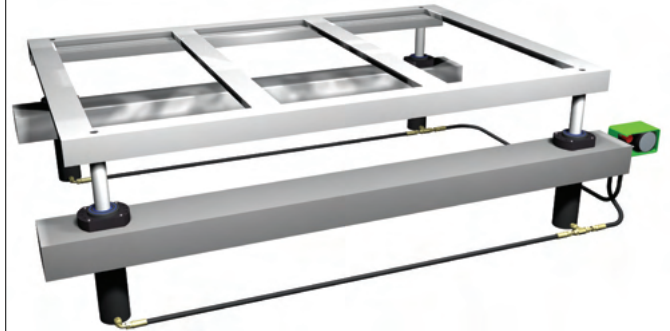

Nitrogen Gas Spring Two Post Lifters – SL2.090, SL2.180 and SL2.300

- Rugged and Reliable Two Post Lift
- Saves Design Time
- Narrow Profile (25 mm, 32 mm & 50 mm)
- Easy to Install
- Ideal for progressive die lifter rail, work holding and balancing applications

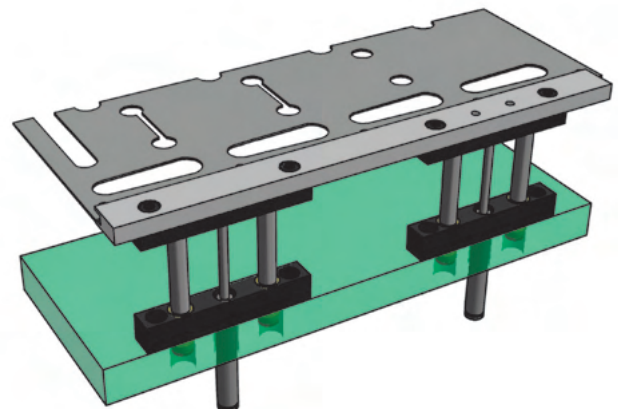

SLN Lifter Technical Data

Maximum Velocity and Attachment Capacity Per Lifter

Ram extension velocity varies by strokes per minute, press stroke and press type. For link or eccentric type presses, the extension velocity may exceed 0.8 m/s (32 in/s). Using the press manufacturer's data, verify that the attachment mass does not exceed recommended limits. Determine ram velocity and reference the recommended attachment mass per lifter. Attachment mass assumes balanced load and actuation force. Do not exceed the ram velocity per lifter. For increased capacity, install external positive stops or add more lifter units to prevent lifter damage.

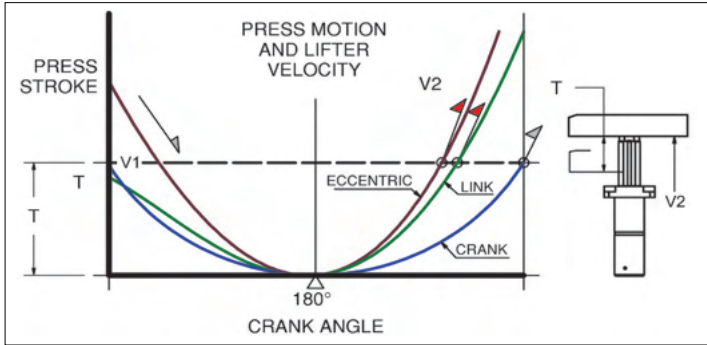

All Lifters			SLN.090		SLN.180 / SLN.300	
Ram Velocity			Attachment Mass			
mm/s	fpm	in/s	kg	lbs-mass	kg	lbs-mass
300	59	12	20	44	31	68
400	79	16	11	25	17	38
500	98	20	7.3	16	11	24
600	118	24	5.0	11	7.7	17
700	138	28	3.7	8	5.6	12
800	157	31	2.8	6	4.3	10

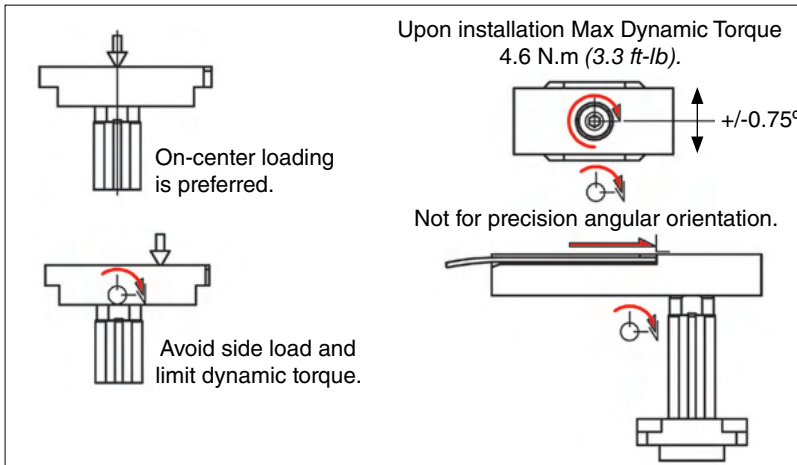

Dynamic Moment Loading		
Torque Max	SLN.090	SLN.180 / SLN.300
lb-in	127	269
lb-ft	11	22
N.m	14	30

Single point lift is not recommended for critical alignment. Use multiple lift points or SL2 Lifter.

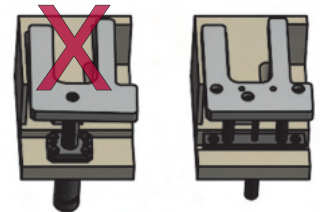

Rail Application for Basic Model Lifters

Rigid attachment is acceptable for single point lifts but should be avoided for rail or plate applications. Use a floating attachment method to avoid binding. Use attachment kit shown below or a similar method. Cushioned shoulder adapters may be used on any SLN lifter. The kit allows for slight misalignment and offset forces in operation. Contact DADCO for more information.

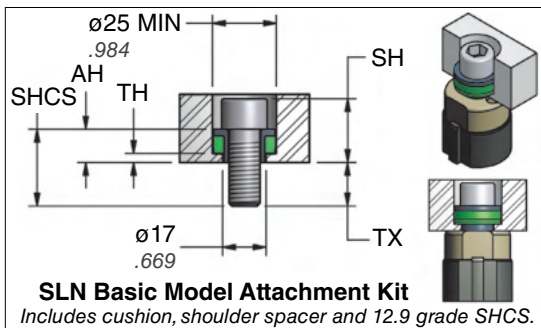

Models (SLN. _)	Part No.*	SHCS	AH		TH		SH		TX	
			mm	inch	mm	inch	mm	inch	mm	inch
090	SLN.090.CB25	M10 x 25	13	0.51	3.5	0.14	23	0.93	12	0.47
090	SLN.090.CB30	M10 x 30	18	0.71	8.5	0.33	28	1.10	12	0.47
090	SLN.090.CB35	M10 x 35	23	0.91	13.5	0.53	33	1.30	12	0.47
180 / 300	SLN.180.CB30	M12 x 30	13	0.51	3.5	0.14	25	0.98	17	0.67
180 / 300	SLN.180.CB35	M12 x 35	18	0.71	8.5	0.33	30	1.18	17	0.67
180 / 300	SLN.180.CB40	M12 x 40	23	0.91	13.5	0.53	35	1.38	17	0.67

*May be used in SL2 Lifter Applications.

Rail Application for Slotted Model Lifters

The slot allows for angular misalignment. Locate the pins to provide maximum angular compensation.

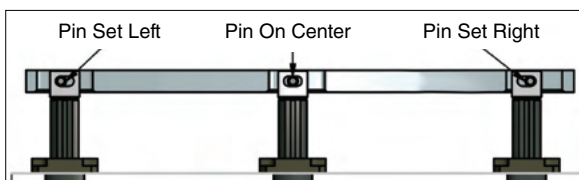

Dampening Sleeve Kit:

SLN.090.____

SKM = 8 mm Pin
SKE = 3/8" Pin

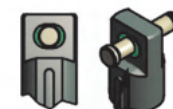

Load Surface

Patented SLN.090 – 90 daN / 200 lb.

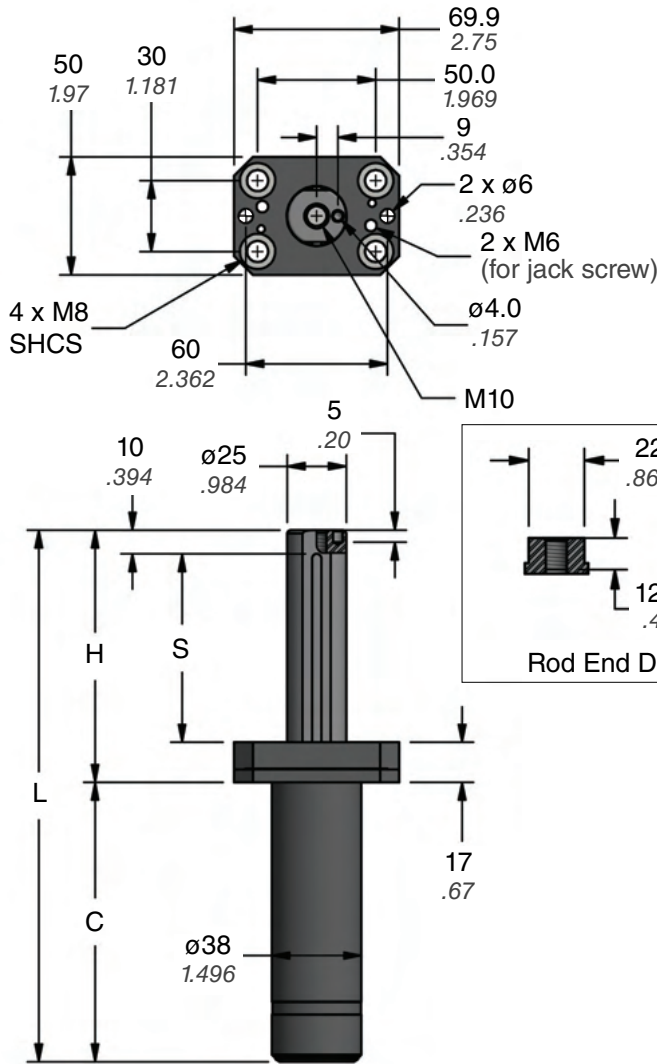

Basic Model

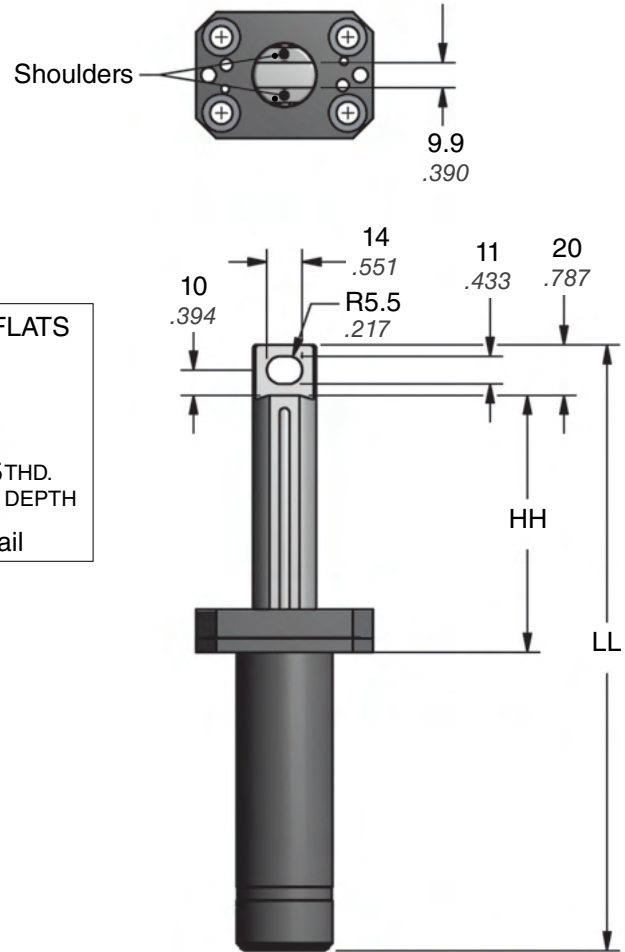

Slotted Model

Part No.	S mm inch	C	Basic		Slotted		Micro Gas Spring
			H	L	HH	LL	
SLN.090.__.025	25 .98	60 2.36	52 2.047	112 4.41	47 1.850	127 5.00	C.090.025.BK
SLN.090.__.038	38 1.50	73 2.87	65 2.559	138 5.43	60 2.362	153 6.02	C.090.038.BK
SLN.090.__.050	50 1.97	85 3.35	77 3.031	162 6.38	72 2.835	177 6.97	C.090.050.BK
SLN.090.__.063	63.5 2.50	101.5 4.00	90.5 3.563	192 7.56	85.5 3.366	207 8.15	C.090.063.BK
SLN.090.__.080	80 3.15	118 4.65	107 4.213	225 8.86	102 4.016	240 9.45	C.090.080.BK
SLN.090.__.100	100 3.94	138 5.43	127 5.000	265 10.43	122 4.803	280 11.02	C.090.100.BK
SLN.090.__.125	125 4.92	163 6.42	152 5.984	315 12.40	147 5.787	330 12.99	C.090.125.BK

On-Contact Force

Metric		Imperial	
bar	daN	psi	lb.
charging pressure	theoretical lifting force	charging pressure	theoretical lifting force
177	89	2560	200
150	75	2200	172
125	63	2000	156
100	50	1750	136
75	38	1500	117
50	25	1000	78
35	17	500	39

See back cover for attachment limitations.

Ordering Example:

SLN.090. B. 050. B32. 150

Part Number:

Includes Series and Model

Rod End Type:

B or S. When not specified, default is B.

Stroke Length:

025, 038, 050, 063, 080, 100 and 125

Charging Pressure of Micro Gas Spring:

35-177 bar (500-2560 psi). When not specified, default is 150 bar.

Mount Option:

B32 = Keyed Narrow Flange Mount

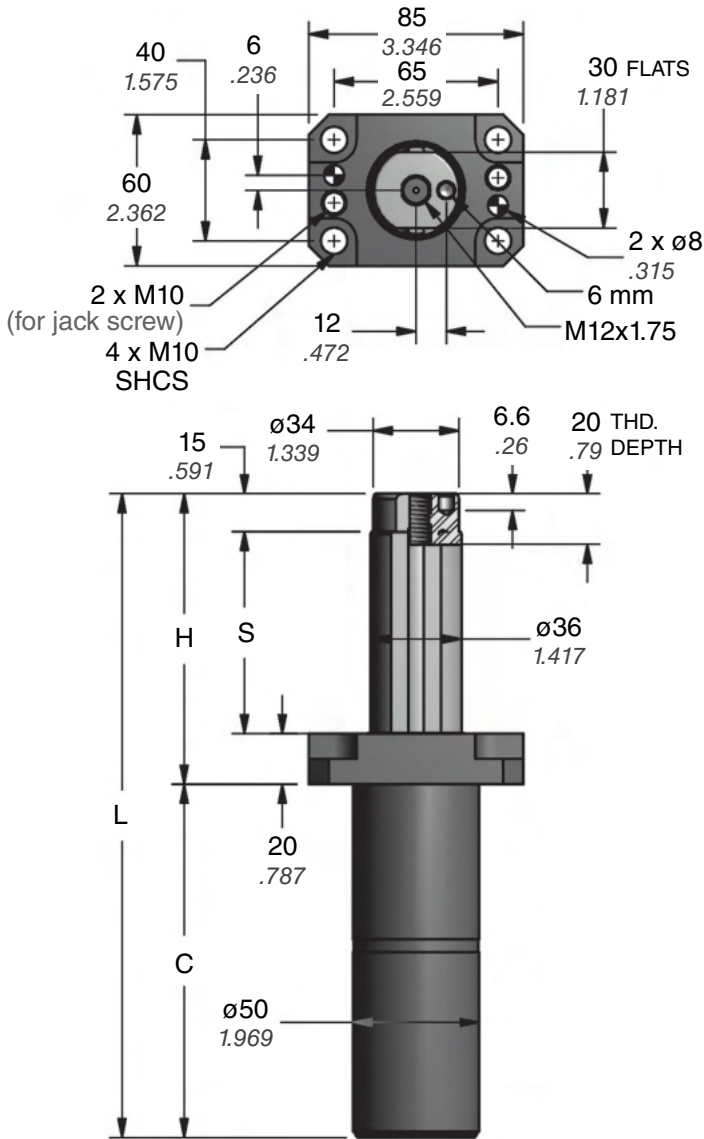

Part No.	S mm <i>inch</i>	C	H	L	Micro Gas Spring
SLN.180.B.025	25 .98	85 3.35	60 2.362	145 5.71	C.180.025.BK
SLN.180.B.038	38 1.50	98 3.86	73 2.874	171 6.73	C.180.038.BK
SLN.180.B.050	50 1.97	110 4.33	85 3.346	195 7.68	C.180.050.BK
SLN.180.B.063	63.5 2.50	123.5 4.86	98.5 3.878	222 8.74	C.180.063.BK
SLN.180.B.080	80 3.15	140 5.51	115 4.528	255 10.04	C.180.080.BK
SLN.180.B.100	100 3.94	160 6.30	135 5.315	295 11.61	C.180.100.BK
SLN.180.B.125	125 4.92	185 7.28	160 6.299	345 13.58	C.180.125.BK

On-Contact Force

Metric		Imperial	
bar	daN	psi	lb.
<i>charging pressure</i>	<i>theoretical lifting force</i>	<i>charging pressure</i>	<i>theoretical lifting force</i>
177	200	2560	450
150	170	2200	387
125	141	2000	351
100	113	1750	307
75	85	1500	263
50	57	1000	175
35	39	500	88

See back cover for attachment limitations.

Ordering Example:

SLN.180. B. 050. B32. 150

Part Number:

Includes Series and Model

Rod End Type:

When not specified, default is B.

Stroke Length:

025, 038, 050, 063, 080, 100 and 125

Charging Pressure of Micro Gas Spring:

35-177 bar (500-2560 psi). When not specified, default is 150 bar.

Mount Option:

B32 = Keyed Narrow Flange Mount

SLN.300 – 3 kN / 1/3 ton

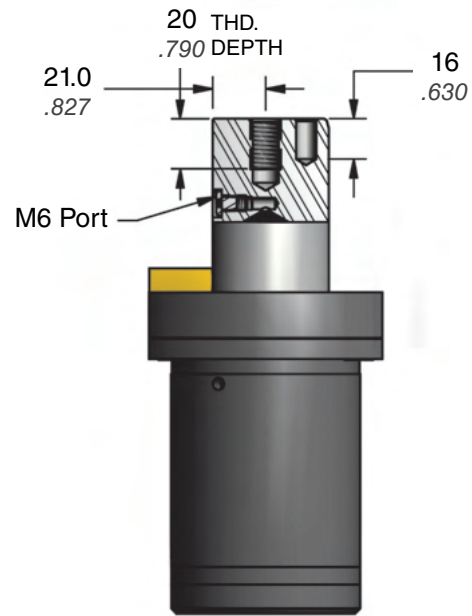
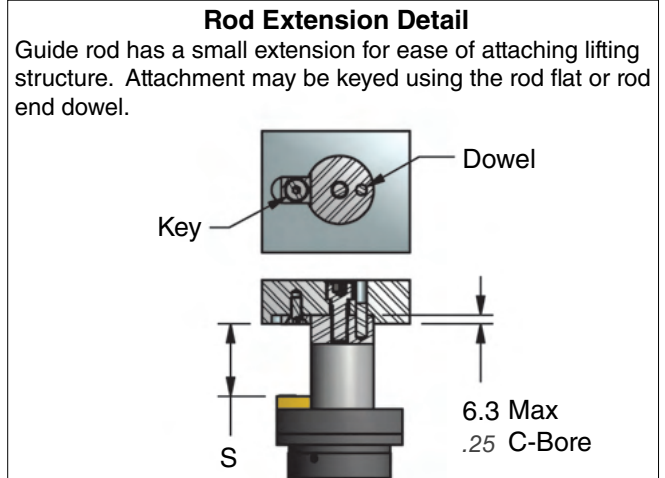
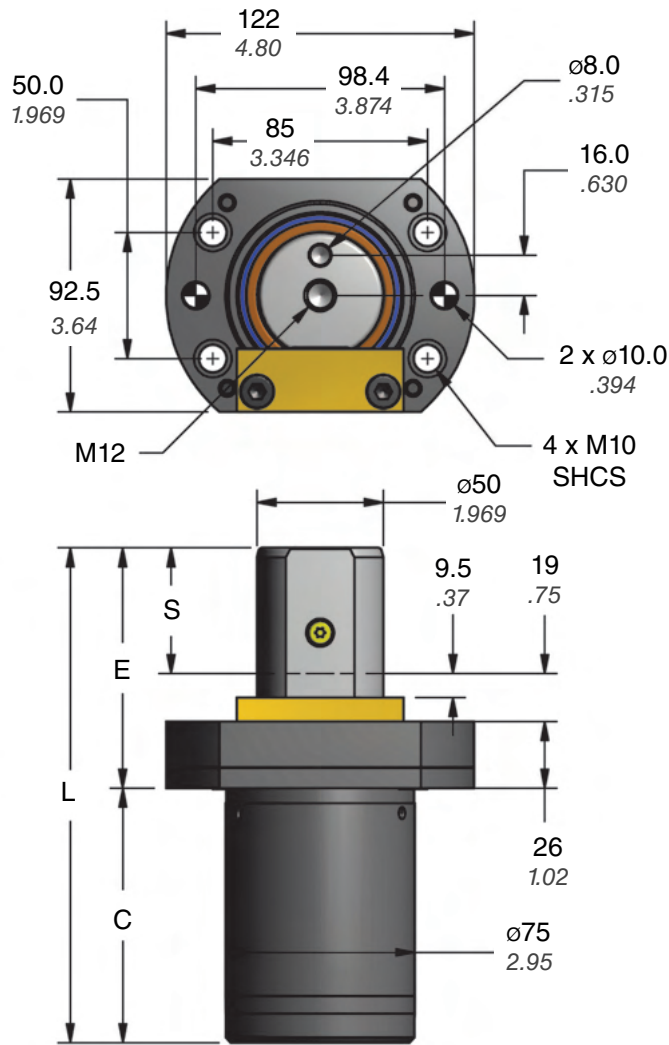

Part No.	S mm inch	C	E	L
SLN.300.050	50 1.97	101 3.98	95 3.740	196 7.717
SLN.300.080	80 3.15	131 5.16	125 4.921	256 10.079
SLN.300.100	100 3.94	151 5.94	145 5.709	296 11.654
SLN.300.125	125 4.92	176 6.93	170 6.693	346 13.622
SLN.300.150	150 5.91	201 7.91	195 7.677	396 15.591

On-Contact Force

Metric		Imperial	
bar charging pressure	daN theoretical lifting force	psi charging pressure	lb. theoretical lifting force
150	302	2175	678
125	251	2000	623
100	201	1750	545
75	151	1500	467
50	101	1000	312
35	68	500	156

See back cover for attachment limitations.

Ordering Example:

SLN.300. 050. B33. 150

Part Number: _____
Includes Series and Model

Stroke Length: _____
050, 080, 100, 125 and 150

Charging Pressure of Micro Gas Spring:
35-150 bar (500-2175 psi). When not specified, default is 150 bar.

Mount Option:
B33 = Keyed Narrow Flange Mount

SL2 Lifter Technical Data

Maximum Velocity and Attachment Capacity Per Lifter

Ram extension velocity varies by strokes per minute, press stroke and press type. For link or eccentric type presses, the extension velocity may exceed 0.8 m/s (32 in/s). Using the press manufacturer's data, verify that the attachment mass does not exceed recommended limits. Determine ram velocity and reference the recommended attachment mass per lifter. Attachment mass assumes balanced load and actuation force. Do not exceed the ram velocity per lifter. For increased capacity, install external positive stops or add more lifter units to prevent lifter damage.

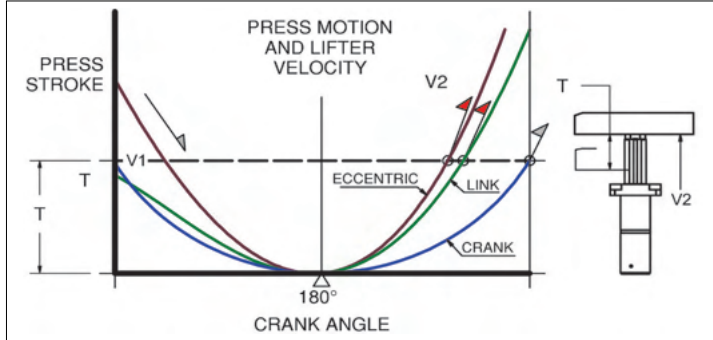

All Lifters			SL2.090		SL2.180		SL2.300	
Ram Velocity			Attachment Mass					
mm/s	fpm	in/s	kg	lbs-mass	kg	lbs-mass	kg	lbs-mass
300	59	12	20	44	31	68	46	102
400	79	16	11	25	17	38	26	57
500	98	20	7.3	16	11	24	17	37
600	118	24	5.0	11	7.7	17	12	25
700	138	28	3.7	8	5.6	12	8	19
800	157	31	2.8	6	4.3	10	6	14

SL2 Installation Guidelines

Rails may be attached to the SL2 lifters with the two or four tapped holes on the top rail plate (Figure 1A). When using multiple lifters, key or dowel the location on only one lifter, to prevent binding (Figure 1B).

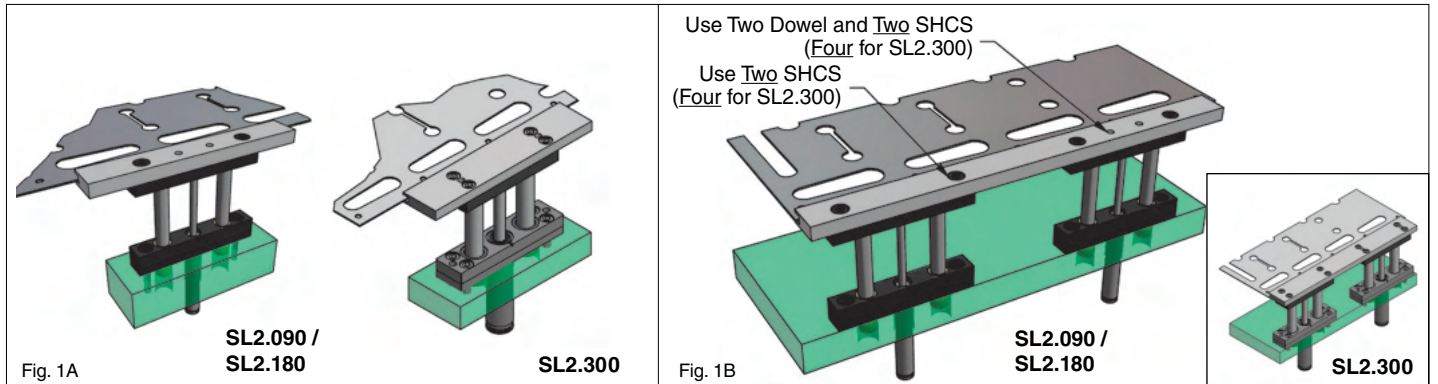

The SL2 lifters may be installed using the basic installation (Figures 2A and 3A). For higher precision, install using the dimensions given in the Precise Installation (Figures 2B and 3B). The bearings will serve as dowels for the SL2.090 and SL2.180. For the SL2.300 the bearing or dowels may be used for precise locating.

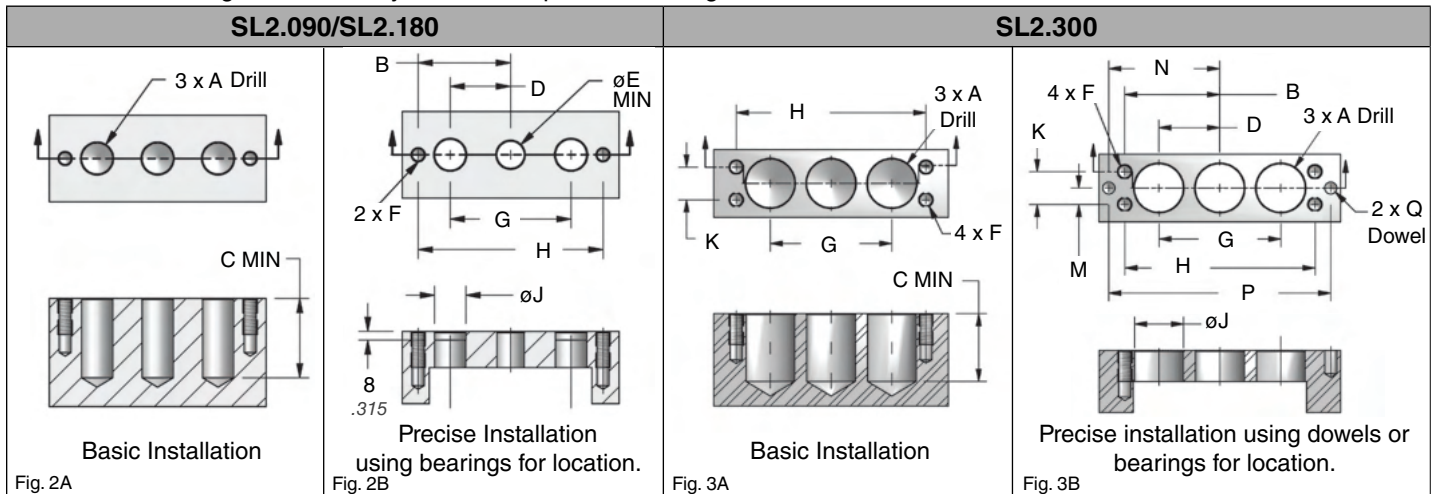

Model		A	B	D	E	F	G	H	J	K	M	N	P	Q
SL2.090	mm	ø22.5	65	42.5	19.1	M10	85	130	22H7	-	-	-	-	-
	inch	7/8	2.559	1.673	.751	3/8"	3.346	5.118	.8665	-	-	-	-	-
SL2.180	mm	ø26.5	75	50	25.1	M12	100	150	26H7	-	-	-	-	-
	inch	1-1/32	2.953	1.969	.988	1/2"	3.937	5.906	1.024	-	-	-	-	-
SL2.300	mm	ø40	78	50	-	M12	100	156	38H7	27	13.5	91	182	ø10
	inch	1-9/16	3.071	1.969	-	1/2"	3.937	6.142	1.496	1.063	.531	3.583	7.165	.394

Patented SL2.090 – 90 daN / 200 lb.

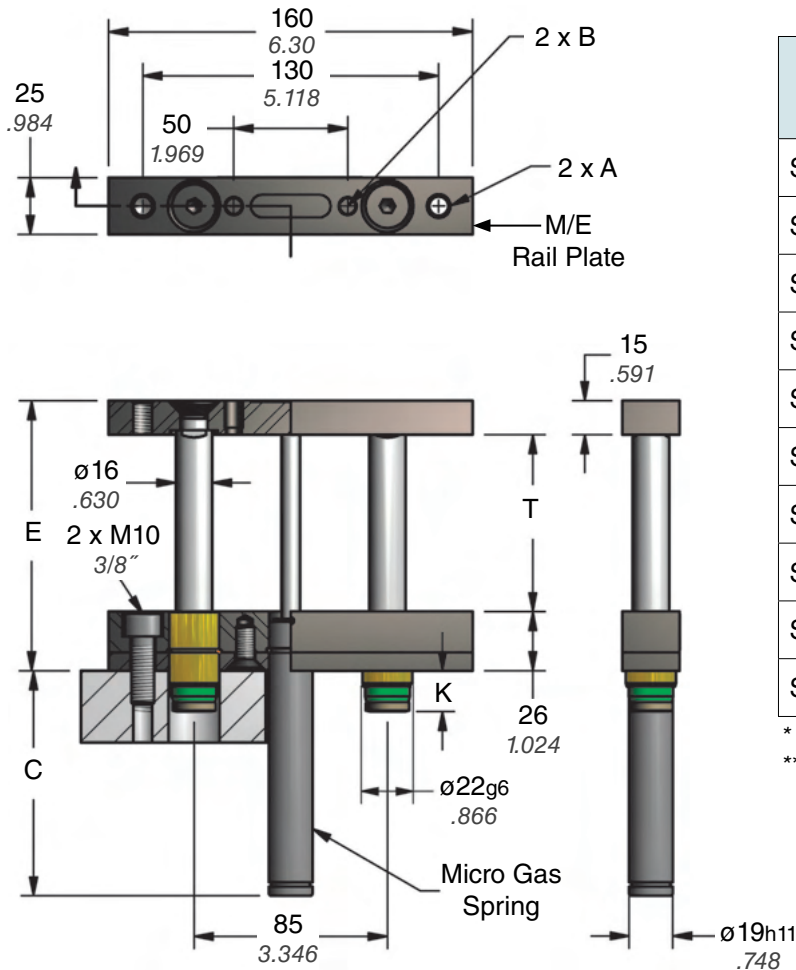

Part No.	T* mm inch	C	E	K	Micro Gas Spring
SL2.090.025**	23 0.91	41 1.61	64 2.520	18 .71	C.090.025.BK
SL2.090.038	36 1.42	54 2.13	77 3.031	18 .71	C.090.038.BK
SL2.090.050	48 1.89	66 2.60	89 3.504	18 .71	C.090.050.BK
SL2.090.063	61.5 2.42	82.5 3.25	102.5 4.035	18 .71	C.090.063.BK
SL2.090.080	78 3.07	99 3.90	119 4.685	18 .71	C.090.080.BK
SL2.090.100	98 3.86	119 4.69	139 5.472	18 .71	C.090.100.BK
SL2.090.125	123 4.84	144 5.67	164 6.457	18 .71	C.090.125.BK
SL2.090.150	148 5.83	177 6.97	189 7.441	26 1.02	C.090.150.BK
SL2.090.175	173 6.81	202 7.95	214 8.425	26 1.02	C.090.175.BK
SL2.090.200	198 7.80	227 8.94	239 9.409	26 1.02	C.090.200.BK

* Gas spring has a 2 mm preload.

** Only available with M1/E1 Rail Plate Option.

Rail Plate	A	øB Dowel
M/M1	M10 x 1.5	8 mm x 12 Deep
E/E1	3/8"-16 UNC	5/16" x .47 Deep

M1/E1 Compact Rail Plate Option

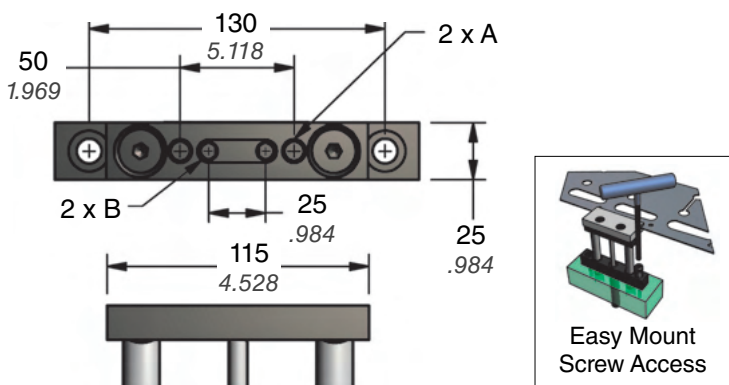

On-Contact Force

Metric		Imperial	
bar charging pressure	daN theoretical lifting force	psi charging pressure	lb. theoretical lifting force
177	89	2560	200
150	75	2200	172
125	63	2000	156
100	50	1750	137
75	38	1500	117
50	25	1000	78
35	17	500	39

See back cover for attachment limitations.

Ordering Example:

SL2.090.050.B5.M.150

Part Number:
Includes Series and Model

Stroke Length:
025, 038, 050, 063, 080, 100, 125, 150,
175 and 200.

Other stroke lengths are available,
contact DADCO for more information.

Charging Pressure of Micro Gas Spring:
35-177 bar (500-2560 psi). When not
specified, default is 150 bar.

Rail Plate:
M, E, M1 or E1. When not specified, default is M.

Mount Option:
B5 = Vertical Mount

Nitrogen Gas Lifters

SL2.180 – 200 daN / 450 lb. *Patented*

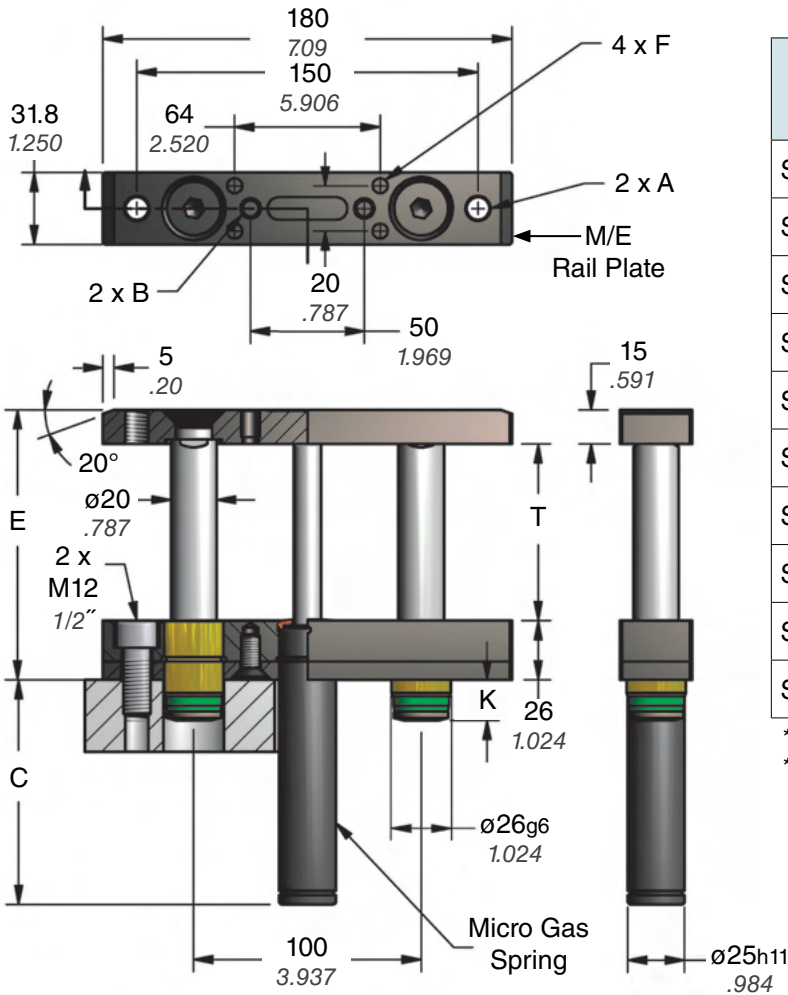

Part No.	T* mm inch	C	E	K	Micro Gas Spring
SL2.180.025**	23 0.91	41 1.61	64 2.520	18 .71	C.180.025.BK
SL2.180.038	36 1.42	54 2.13	77 3.031	18 .71	C.180.038.BK
SL2.180.050	48 1.89	66 2.60	89 3.504	18 .71	C.180.050.BK
SL2.180.063	61.5 2.42	82.5 3.25	102.5 4.035	18 .71	C.180.063.BK
SL2.180.080	78 3.07	99 3.90	119 4.685	18 .71	C.180.080.BK
SL2.180.100	98 3.86	119 4.69	139 5.472	18 .71	C.180.100.BK
SL2.180.125	123 4.84	144 5.67	164 6.457	18 .71	C.180.125.BK
SL2.180.150	148 5.83	177 6.97	189 7.441	26 1.02	C.180.150.BK
SL2.180.175	173 6.81	202 7.95	214 8.425	26 1.02	C.180.175.BK
SL2.180.200	198 7.80	227 8.94	239 9.409	26 1.02	C.180.200.BK

* Gas spring has a 2 mm preload.

** Only available with M1/E1 Rail Plate Option.

Rail Plate	A	øB Dowel	F
M/M1	M12 x 1.75	10 mm x 12 Deep	M8 x 1.25
E/E1	1/2"-13 UNC	3/8" x .47 Deep	5/16"-18

M1/E1 Compact Rail Plate Option

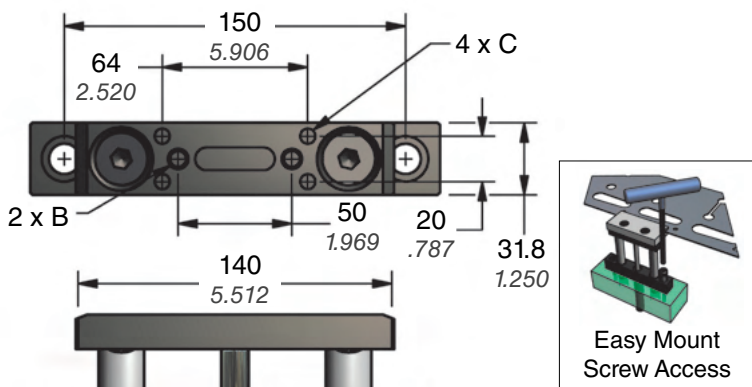

On-Contact Force

Metric		Imperial	
bar charging pressure	daN theoretical lifting force	psi charging pressure	lb. theoretical lifting force
177	200	2560	450
150	170	2200	387
125	141	2000	351
100	113	1750	307
75	85	1500	263
50	57	1000	176
35	39	500	88

See back cover for attachment limitations.

Ordering Example:

SL2.180. 050. B5. M. 150

Part Number:

Includes Series and Model

Stroke Length:

025, 038, 050, 063, 080, 100, 125, 150, 175 and 200.

Other stroke lengths are available, contact DADCO for more information.

Charging Pressure of Micro Gas Spring:

35-177 bar (500-2560 psi). When not specified, default is 150 bar.

Rail Plate:

M, E, M1 or E1. When not specified, default is M.

Mount Option:

B5 = Vertical Mount

SL2.300 – 3 kN / 1/3 ton

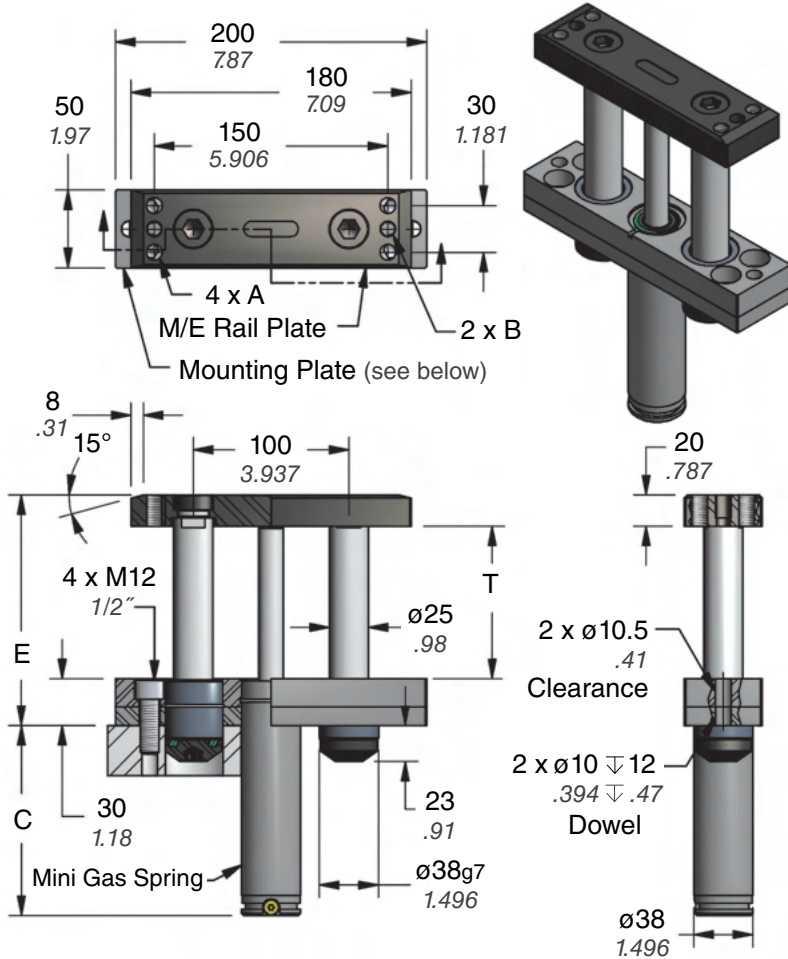

Part No.	T* mm inch	C	E	Mini Gas Spring
SL2.300.025**	23 0.91	47 1.85	73 2.874	L.300.025
SL2.300.038	35.5 1.40	59.5 2.34	85.5 3.366	L.300.038
SL2.300.050	48 1.89	72 2.83	98 3.858	L.300.050
SL2.300.063	60.5 2.38	84.5 3.33	110.5 4.350	L.300.063
SL2.300.080	78 3.07	102 4.02	128 5.039	L.300.080
SL2.300.100	98 3.86	122 4.80	148 5.827	L.300.100
SL2.300.125	123 4.84	147 5.79	173 6.811	L.300.125
SL2.300.150	148 5.83	172 6.77	198 7.795	L.300.150
SL2.300.175	173 6.81	197 7.76	223 8.780	L.300.175
SL2.300.200	198 7.80	222 8.74	248 9.764	L.300.200

* Available gas spring travel.

** Only available with M1/E1 Rail Plate Option.

Rail Plate	A	øB Dowel
M/M1	M12 x 1.75	10 mm x 15 Deep
E/E1	1/2"-13 UNC	3/8" x .59 Deep

Mounting Plate Detail and M1/E1 Compact Rail Plate Option

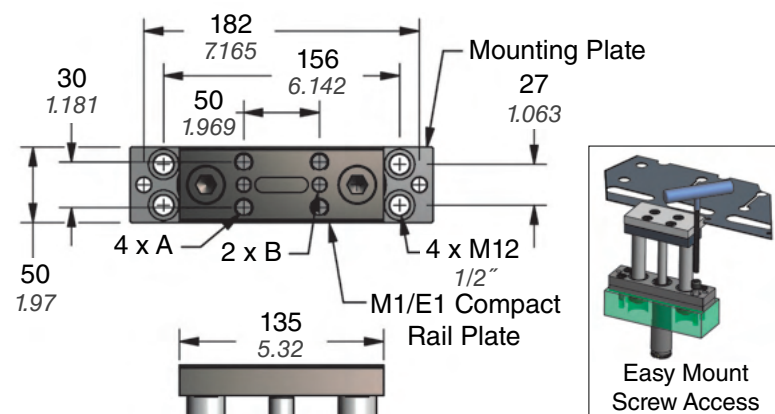

On-Contact Force

Metric		Imperial	
bar charging pressure	daN theoretical lifting force	psi charging pressure	lb. theoretical lifting force
150	302	2175	678
125	251	2000	623
100	201	1750	545
75	151	1500	467
50	101	1000	312
35	68	500	156

See back cover for attachment limitations.

Ordering Example:

SL2.300. 050. B5. M. 150

Part Number: _____
Includes Series and Model

Stroke Length: _____
025, 038, 050, 063, 080, 100, 125,
150, 175 and 200.

Other stroke lengths are available,
contact DADCO for more information.

Charging Pressure of Micro Gas Spring:
35-150 bar (500-2175 psi). When not
specified, default is 150 bar.

Rail Plate:
M, E, M1 or E1. When not specified, default is M.

Mount Option:
B5 = Vertical Mount

Maximum Velocity and Attachment Capacity Per Lifter

Ram extension velocity varies by strokes per minute, press stroke and press type. For link or eccentric type presses, the extension velocity may exceed 0.8 m/s (32 in/s). Using the press manufacturer's data, verify that the attachment mass does not exceed recommended limits. Determine ram velocity and reference the recommended attachment mass per lifter. Attachment mass assumes balanced load and actuation force. Do not exceed the ram velocity per lifter. For increased capacity, install external positive stops or add more lifter units to prevent lifter damage.

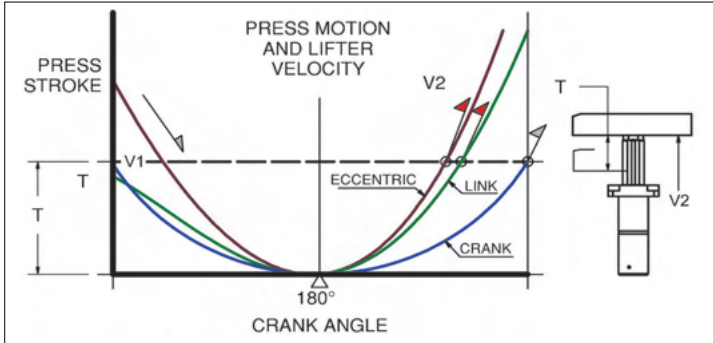

All Lifters			SLC.500		SLC.800*	
Ram Velocity			Attachment Mass			
mm/s	fpm	in/s	kg	lbs-mass	kg	lbs-mass
300	59	12	20	44	31	68
400	79	16	11	25	17	38
500	98	20	7.3	16	11	24
600	118	24	5.0	11	7.7	17
700	138	28	3.7	8	5.6	12
800	157	31	2.8	6	4.3	10

*SLC.800 may have production rate limits depending upon charging pressure.

Rod Extension Detail

Guide Rod has a small extension for ease of attaching lifting structure.

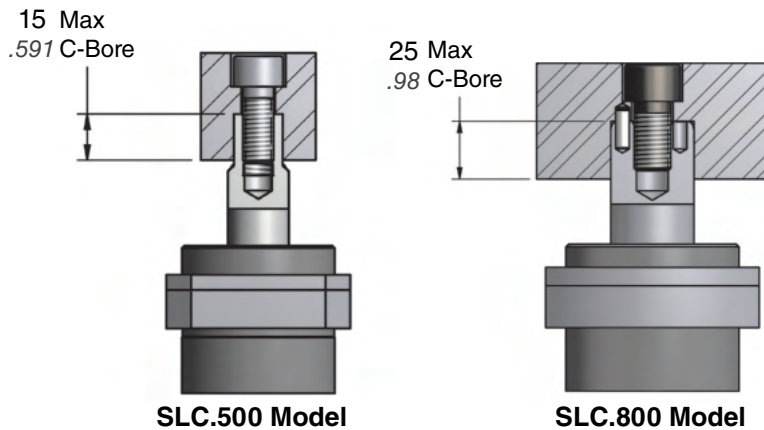

SLC Internal Cushion

Distance of cushion travel is dependent on attachment mass and charging pressure.

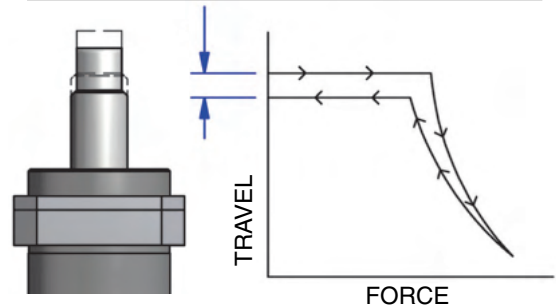

Model		Minimum	Maximum
SLC.500	mm	2	4
	inch	.08	.16
SLC.800	mm	3	6
	inch	.12	.24

SLC.500 On-Contact Force

Metric

bar charging pressure	daN theoretical lifting force
70	220
50	157
40	126
25	79

Imperial

psi charging pressure	lb. theoretical lifting force
1000	487
750	365
500	244
250	122

SLC.800 On-Contact Force

Metric

bar charging pressure	daN theoretical lifting force
70	712
50	509
40	407
25	254

Imperial

psi charging pressure	lb. theoretical lifting force
1000	1578
750	1184
500	789
250	395

Higher charging pressures are available for non-attachment loading, please contact DADCO for application and installation evaluation.

SLC.500 – 5 kN / ½ ton & SLC.800 – 7 kN / ¾ ton

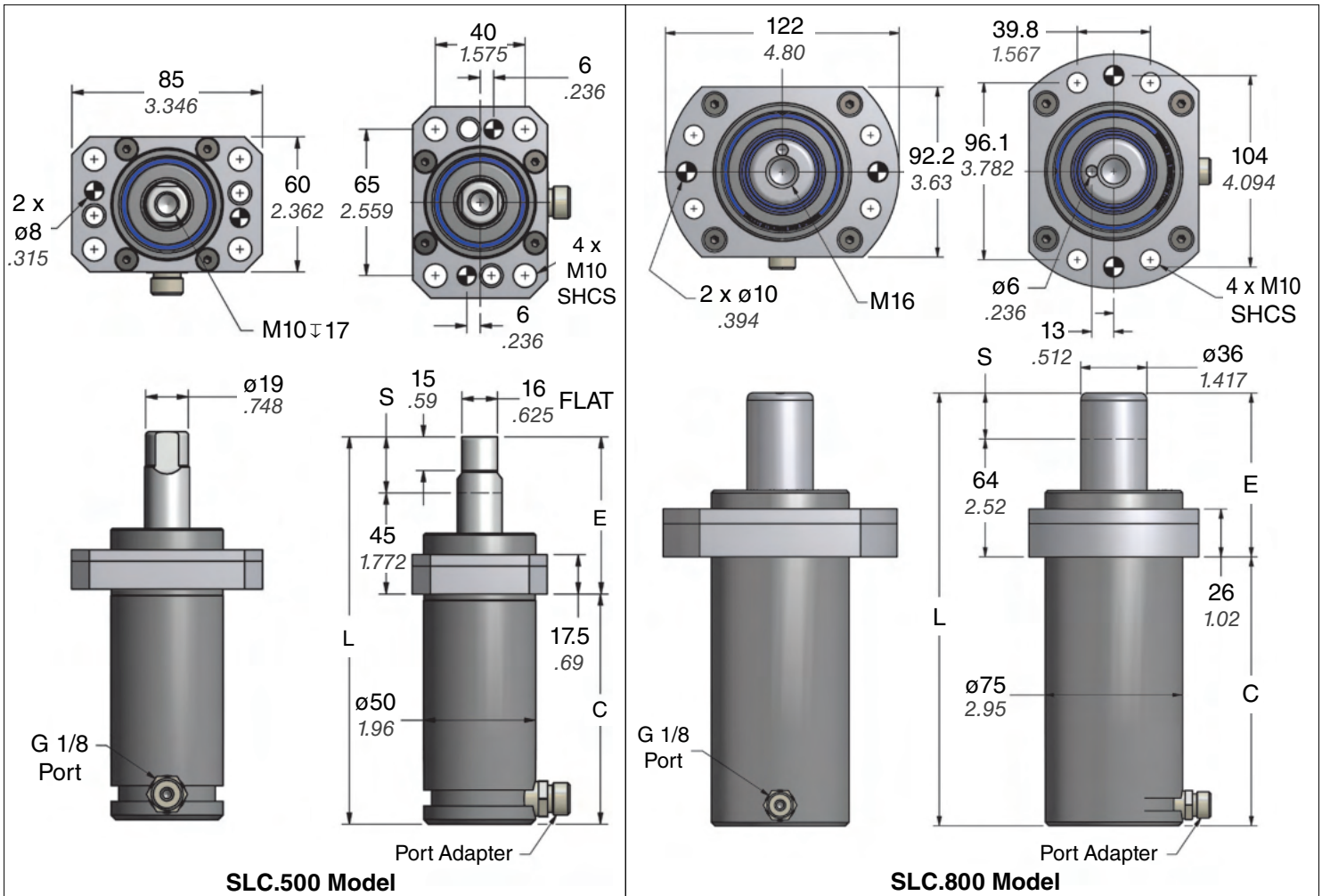

Part No.	S mm inch	SLC.500 Model			SLC.800 Model		
		C	E	L	C	E	L
SLC.___.B.050	50 1.97	127.5 5.02	95 3.740	222.5 8.760	190 7.48	114 4.488	304 11.969
SLC.___.B.080	80 3.15	157.5 6.20	125 4.921	282.5 11.122	220 8.66	144 5.669	364 14.331
SLC.___.B.100	100 3.94	177.5 6.99	145 5.709	322.5 12.697	240 9.45	164 6.457	404 15.906
SLC.___.B.125	125 4.92	202.5 7.97	170 6.693	372.5 14.665	265 10.43	189 7.441	454 17.874
SLC.___.B.150	150 5.91	227.5 8.96	195 7.677	422.5 16.634	290 11.42	214 8.425	504 19.843
SLC.___.B.175	175 6.89	252.5 9.94	220 8.661	472.5 18.602	315 12.40	239 9.409	554 21.811
SLC.___.B.200	200 7.87	277.5 10.93	245 9.646	522.5 20.571	340 13.39	264 10.394	604 23.780

Ordering Example:

SLC.800. B. 050. B34. F

Part Number: _____
Includes Series and Model (500 or 800)

Rod End Tap: _____
B = Basic Model

For Retrofit options, contact DADCO.

Stroke Length: _____
050, 080, 100, 125, 150, 175 and 200.

Specify Open Flow Fitting:

F = 90.505.115 (ORFS)

FD = 90.508.115 (D-24)

When not specified, default is F.

Mount Option:

B34 = Narrow Flange Mount

SLN.180 Flange Model *Special Application*

DADCO's SLN.180 Flange Model Micro Nitrogen Gas Lifter meets Ford Die Standards (WDX06-80M) for stamping components. Two models are available to accommodate flange stripper applications: FA with a conical rod and rod locator for attachment to the upper die; and FB with a flat rod end.

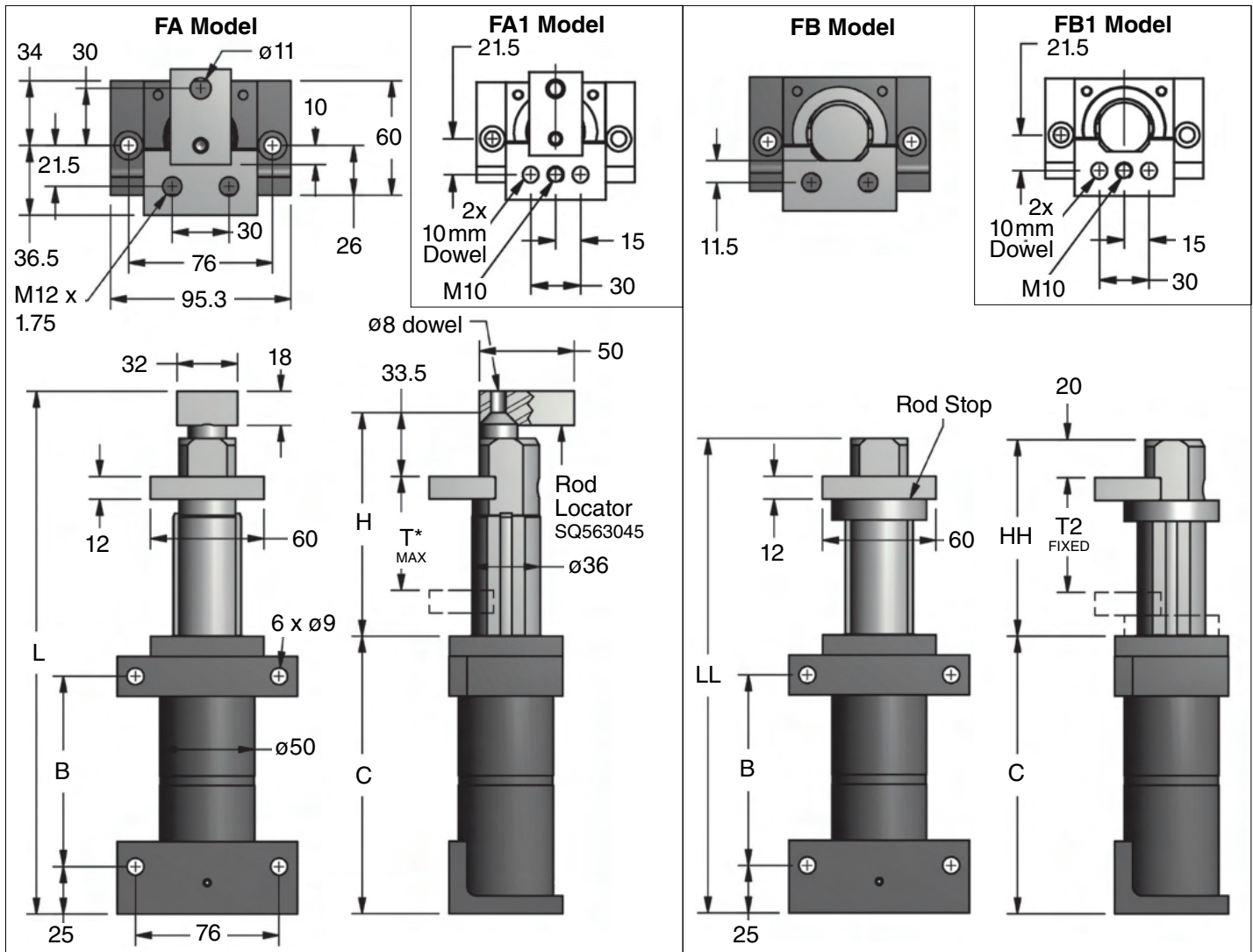

Part No.	C mm	B	FA / FA1 Model			FB / FB1 Model			Micro Gas Spring
			T*	H	L	T2	HH	LL	
SLN.180.__.063	146	100	60	117.5	275	60	104	250	C.180.063.BK
SLN.180.__.080	162.5	116.5	72	134	308	72	120.5	283	C.180.080.BK
SLN.180.__.100	182.5	136.5	90	154	348	90	140.5	323	C.180.100.BK
SLN.180.__.125	207.5	161.5	112	179	398	112	165.5	373	C.180.125.BK
SLN.180.__.150	240.5	194.5	135	204	456	135	190.5	431	C.180.150.BK
SLN.180.__.175	265.5	219.5	157	229	506	157	215.5	481	C.180.175.BK
SLN.180.__.200	290.5	244.5	180	254	556	180	240.5	531	C.180.200.BK

*Maximum recommended travel

Ordering Example:

SLN.180. FA1. 063. B35. BK.20

Part Number:

Includes Series and Model

Rod End Type:

Specify Flange Style FA, FA1, FB or FB1

Stroke Length:

063, 080, 100, 125, 150, 175 and 200

Charging Pressure of Micro Gas Spring:

RD, BU, GR

BK = 20-135 bar (290-1920 psi).

When not specified, default is BK.20 = 20 bar.

Mount Option:

B35 = Keyed Vertical Mount

SLN.180 Flange Model

Force Chart	Initial lb. daN	Final lb. daN	Pressure psi bar
Red - RD	337 149	459 204	1920 132
Blue - BU	224 100	306 136	1280 88
Green - GR	112 50	153 68	640 44
Black - BK	See Charts		

Metric		Imperial	
bar charging pressure	daN theoretical lifting force	psi charging pressure	lb.-f theoretical lifting force
30	34	450	79
20	23	290	51

Application Examples

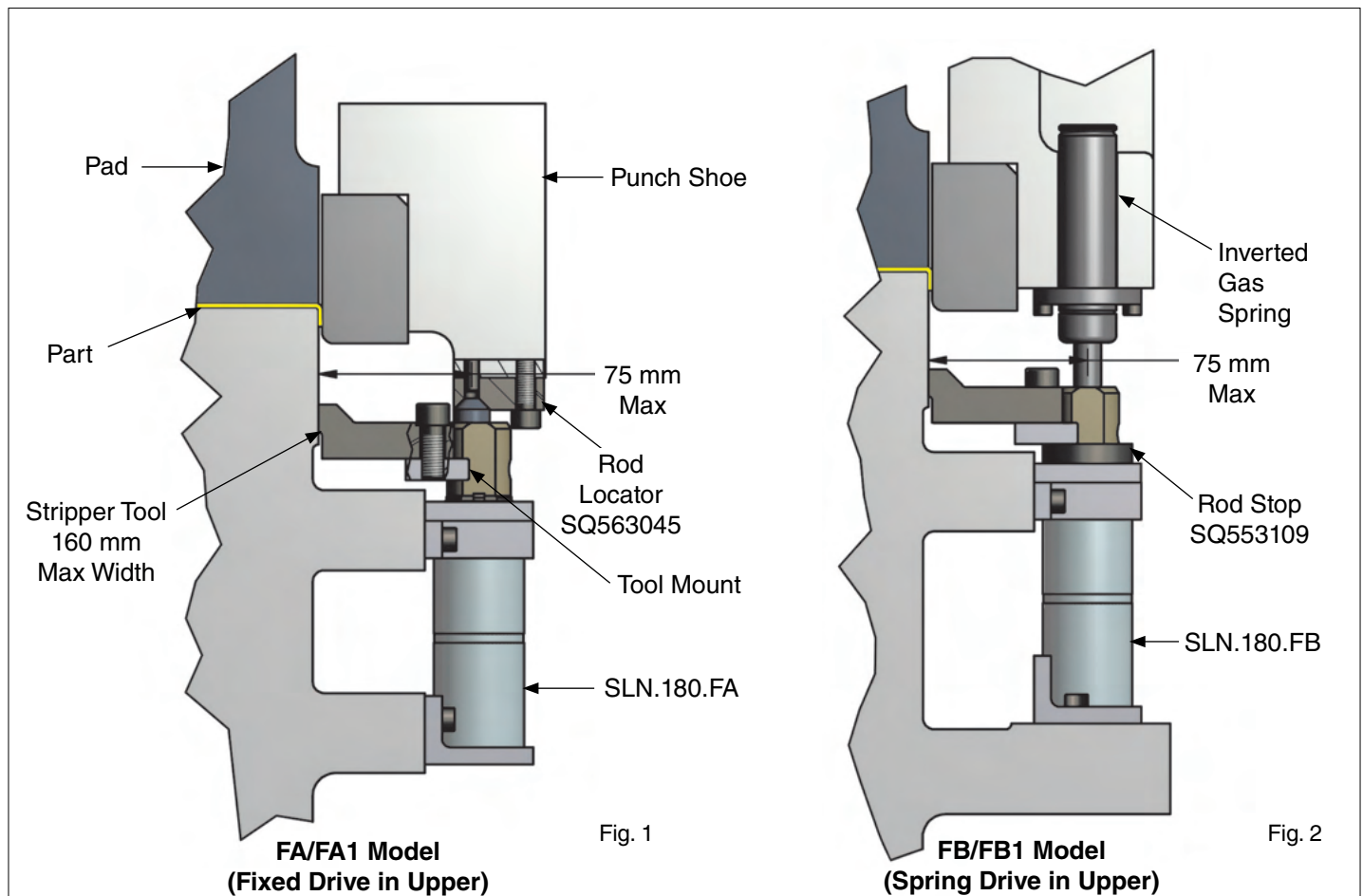

The SLN.180.FA is installed in a flange application with the Stripper Tool mounted to the lifter's Tool Mount, shown in Figure 1. As the Punch Shoe retracts, the tool strips the part from the die. The lifter's Rod Locator (SQ563045) is attached to the Punch Shoe and is used for guidance of the lifter's rod during operation. To maximize reliability do not exceed an offset of 75 mm from the edge of the die to the centerline of the rod and keep the Stripper Tool width under 160 mm.

The SLN.180.FB is used in a flange application when the pad travel is greater than the flange stripper travel, shown in Figure 2. The Rod Stop (SQ553109) is provided to prevent over-travel of the guide rod. An inverted nitrogen gas spring mounted in the upper makes direct contact with the rod end during operation.

The SLN.180.FB model may also be used in conventional lifter applications with modification to the rod end, contact DADCO for more information.

Operating Specifications

Lifter Model	Gas Spring Used	Maximum Charging Pressure	Operating Temperature Range	Maximum Speed
SL2.090	C.090	177 bar (2560 psi)	4° C – 71° C (40°F – 160°F)	1.6 m/sec (63 in/sec)
SL2.180	C.180			
SLN.090	C.090			
SLN.180	C.180			
SL2.300	L.300	150 bar (2175 psi)		
SLN.300	Integral			
SLC.500	Integral	70 bar (1000 psi)		
SLC.800	Integral			

Lifter Loading and Center of Gravity

To maximize reliability of stand-alone lifters, actuate as close to F_A as possible. Good design practice should minimize L and locate F_{CG} on the centerline of the lifter. Increased wear on the bearing will occur if L exceeded 50 mm or if F_A is offset from the centerline. If large offset is required, reduce attachment load or add additional lifters.

- On-center loading is preferred
- Avoid side load and limit dynamic torque

Dynamic Moment Loading					
Torque Max	SLN.090	SLN.180 / SLN.300	SL2.090	SL2.180	SL2.300
lb-in	127	269	122	163	131
lb-ft	11	22	10	14	11
N.m	14	30	14	18	15

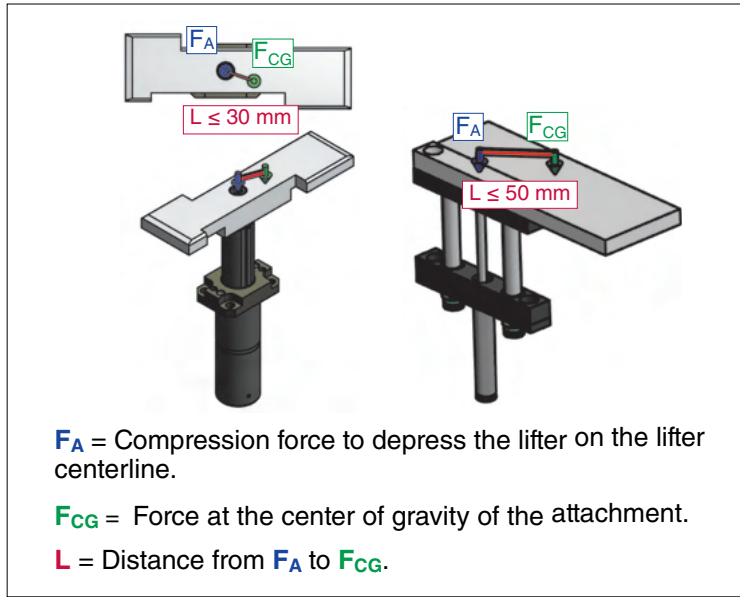

Repair Kits

Lifter Model	Kit Number	Description
SL2.090	SL2.RK.090 (25-125 mm strokes) SL2.RL.090 (150, 175 and 200 mm strokes)	Repair kit includes bearing with snap rings (2), dampening devices (2) and a maintenance manual.
SL2.180	SL2.RK.180 (25-125 mm strokes) SL2.RL.180 (150, 175 and 200 mm strokes)	Repair kit includes bearing with snap rings (2), dampening devices (2) and a maintenance manual.
SL2.300	SL2.RK.300	Repair kit includes bearing assemblies with snap rings (2), dampening devices (2) and a maintenance manual.
SLN.090	SLN.RK.090	Repair kit includes bearing, piston rider, rod keys (2), assembly grease and a maintenance manual.
SLN.180	SLN.RK.180	Repair kit includes bearing, piston rider, rod keys (2), assembly grease and a maintenance manual.
SLN.300	SLN.RK.300	SLN.300 Repair Kit includes dust cover, bearing, cartridge assembly, piston rider, set screws, bottle of assembly oil, assembly grease and a maintenance manual.
SLC.500	SLC.RK.500	SLC.500 Repair Kit includes dust cover, cushion collar assembly, cartridge assembly, bottle of assembly oil and a maintenance manual.
SLC.800	SLC.RK.800	SLC.800 Repair Kit includes dust cover, cushion collar assembly, cartridge assembly, bottle of assembly oil and a maintenance manual.