

This bulletin is a simple step-by-step maintenance guide for DADCO's HP Series Air Cylinders. Proper repair requires careful examination of all component parts and replacement of any that are worn or damaged. All DADCO replacement parts are available from factory stock. After reviewing this maintenance guide, if you require any additional training or have any questions please contact DADCO for assistance.

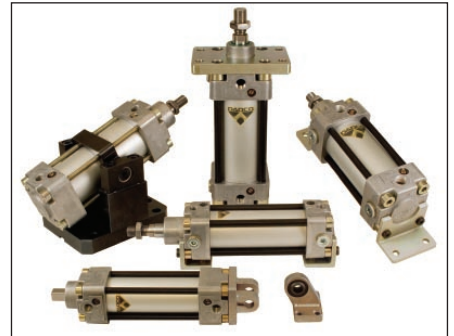

CAUTION: Always wear safety goggles when performing any maintenance work.

Repair Kit Instructions

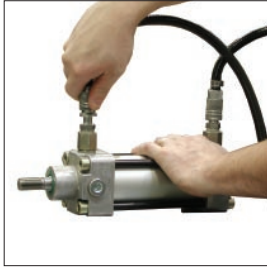

1. Unhook the cylinder from the air supply.

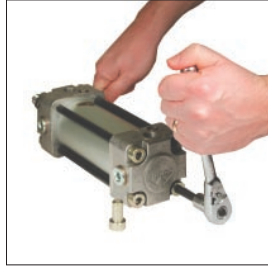

2. Remove the tie rod nuts from the rear head using a socket drive allen wrench. Retain nuts for use during reassembly.



3. Remove the tie rods then remove the front head assembly.



4. Remove the dampening washer, save for reassembly.



5. Remove the front cushion seal and discard.



6. Insert the new front cushion seal with the flat side down. Reinstall the dampening washer, be sure to line up the washer with the groove in the head.

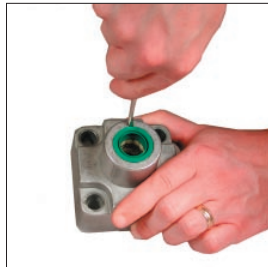

7. Use the notch in the head to remove the rod seal. Be careful not to damage or scratch the inside of the head. Discard the rod seal.



8. Remove the plastic bearings using a screwdriver to pop them out. Be careful not to damage or scratch the inside of the head.



9. Replace the bearings by snapping them into the grooves.



10. Install the new rod seal and set the front head aside for cylinder reassembly.



11. Remove the rod and piston assembly.



12. Remove and replace the piston seals, be careful not to scratch the surface of the piston. Guide tape will be loose and can be easily removed from the piston. Make sure the guide tape is in place before installation.

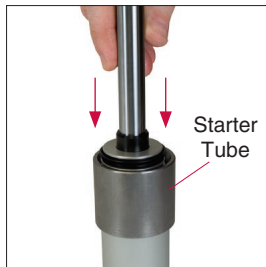

13. For installation of the rod and piston assembly use DADCO's Starter Tube (refer to page 2). Place the starter tube on top of the tube and carefully guide the rod and piston assembly into the tube. Maintain alignment and ensure the piston seals and guide tape remain in place.

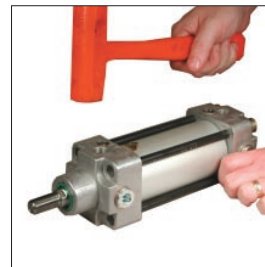

14. Replace the front head ensuring alignment of the ports between the front and rear heads, then insert the four tie rods. To ensure proper alignment, square the heads using a flat surface (ex., granite block).



15. Replace the tie rod nuts using a medium strength liquid thread locker on the threads before re-installing. Alternate tightening of each tie rod nut a half turn until all tie rod nuts are secure. See page 2 for torque values. This completes the repair of your HP Series Air Cylinder.

NOTE: If necessary, remove the rear head to replace the rear cushion seal, performing steps 3-6 on the rear head.

HP Series Air Cylinder Repair Kit Installation

HP Series Repair Kit Installation

Parts List

Starter Tube

Use the starter tube to guide the piston and rod assembly into the tube.

HP.350.040	HP.350.080
HP.350.050	HP.350.100
HP.350.063	HP.350.125

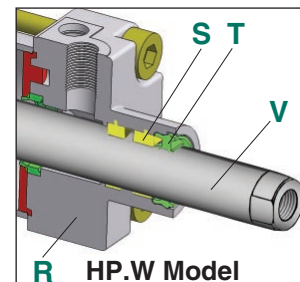
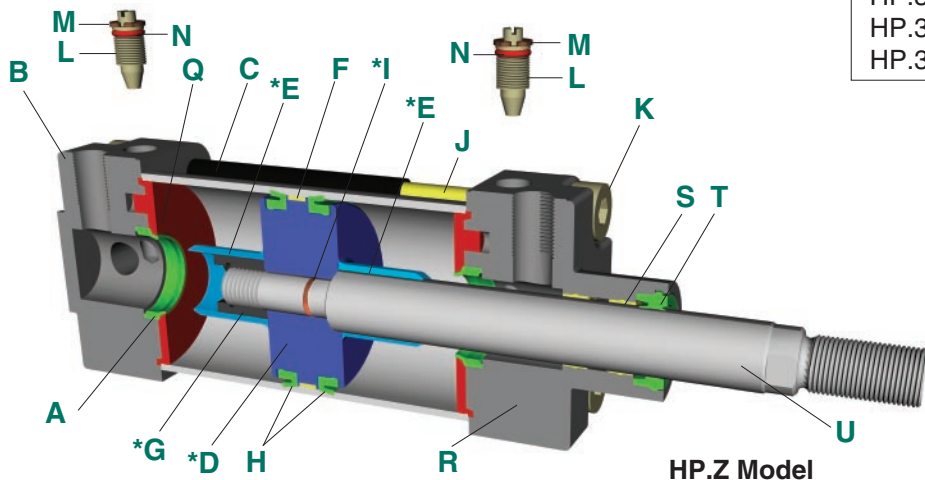

NOTE: For bore diameters $\phi 32$ and $\phi 160$ - $\phi 250$, please contact DADCO.

Parts List	Quantity Required	$\phi 40$	$\phi 50$	$\phi 63$	$\phi 80$	$\phi 100$	$\phi 125$
A Cushion Seal	2	IQ470950	IR470951	IS470951	IT470953	IU470954	IV470955
B Rear Head	1	IQ600461	IR600462	IS600463	IT600214	IU600215	IV600216
C Tube	1	IQ05Z__	IR05Z__	IS05Z__	IT05Z__	IU05Z__	IV05Z__
F Guide Tape	1	IQ417726	IR417727	IS417728	IT417521	IU417467	IV41V360
H Piston Seal	2	IQ480970	IR480971	IS480972	IT480973	IU480974	IV47V359
J Tie Rod	4	IQ75M__	IR75M__	IS75M__	IT75M__	IU75M__	IV75M__
K Tie Rod Nut <i>Torque Value</i>	8	IP852201 8 lbs.ft.	IR852203 18 lbs.ft.	IS852203 18 lbs.ft.	IT852205 34 lbs.ft.	IT852205 34 lbs.ft.	IV850313 62 lbs.ft.
L Regulating Screw	2	IQ502241	IR502242	IS502243	IT502244	IU502245	IV502246
M Retaining Ring	2	IP857278	IR857279	IS857280	IS857280	IU857281	IV857282
N Adj. Screw O-Ring	2	IP450979	IR450981	IS450982	IT450983	IU450984	IV450985
Q Dampening Washer	2	IQ450861	IR450862	IS450863	IT450864	IU450865	IV450866
HP.Z Model							
R Front Head	1	IQ600451	IR600452	IS600453	IT600204	IU600205	IV600206
S Rod Bearing	2	90.240.00300	90.240.00500	90.240.00500	90.240.00750	90.240.01500	90.240.U.2600
T Rod Seal/Wiper/Ring	1	IQ47V230	IR47V231	IR47V231	IT47V232	IU47V233	IV47V234
**U Piston Rod Assembly	1	IQ00Z__	IR00Z__	IS00Z__	IT00Z__	IU00Z__	IV00Z__
HP.W Model							
**V Piston Rod Assembly	1	IQ00W__	IR00W__	IS00W__	IT00W__	IU00W__	IV00W__
Seal Kit <i>Contains A, H & T</i>		IQ009181	IR009182	IS009183	IT009184	IU009185	IV009186
Repair Kit <i>Contains A, H, S & T</i>		IQ009191	IR009192	IS009193	IT009194	IU009195	IV009196

* Not sold separately: Piston (D), Piston O-Ring (I), Piston Nut (G) and Cushion Spears (E).

** Includes D, I, G and E. When ordering, please note the stroke length in addition to the part number.

Every effort has been made to have all illustrations and drawings accurately represent the product as it was at the time this bulletin was printed. However, so that we effectively may continue to meet the requirements of DADCO customers, some product changes may occur during the life of this bulletin without prior notice.