

Two Post Direct Lift

HP Series Air Cylinders

DADCO's Two Post Direct Lift delivers smooth, consistent lifting action and operates non-lube. It is available in a variety of bore sizes and stroke lengths to accommodate different applications. The Direct Lift has a simple, no maintenance construction consisting of an HP Air Cylinder and two guide rods. The hardened guide rods are supported by premium roller bearings.

The upper plate features a convenient bolt pattern, common to all the bore sizes. Fixtures easily can be mounted in place; no welding or extra machining is required. The upper plate can be removed and altered if necessary to accommodate customer specific applications, request Bulletin No. B01126 for further information.

Two Post Direct Lift

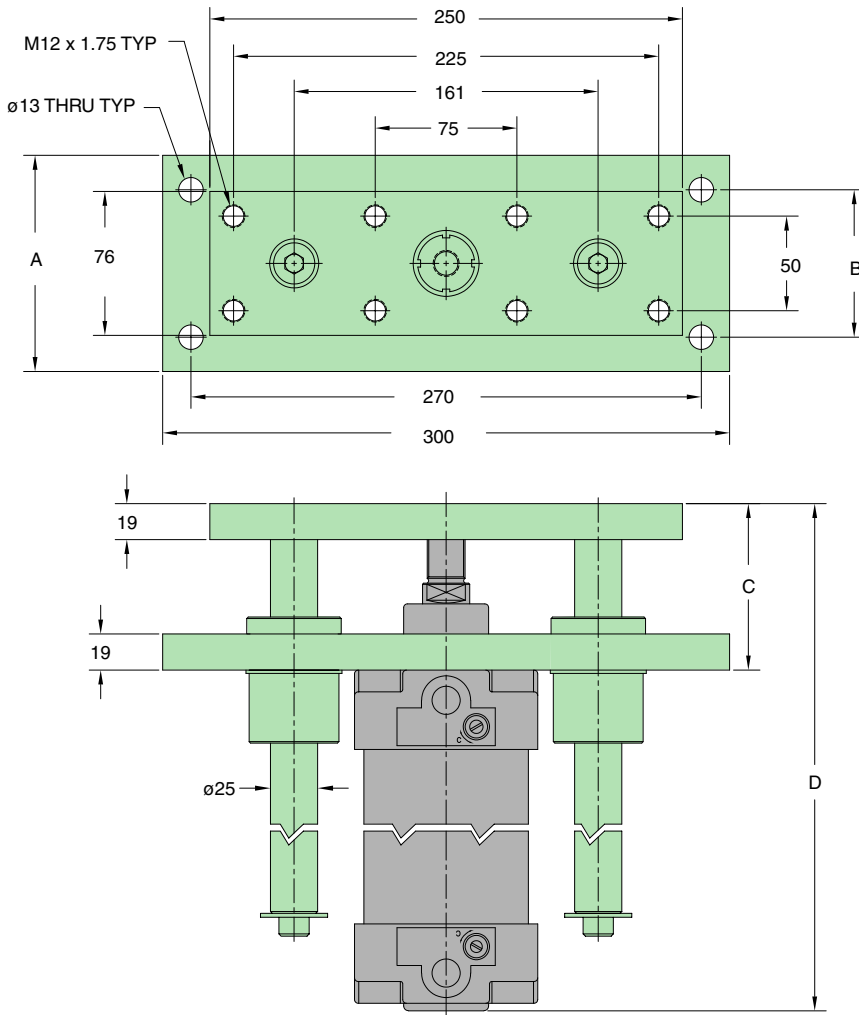

Standard TDL2

Bore	A	B	C	D
40	76	50	56	165 + S
50	76	50	56	181 + S
63	76	50	56	196 + S
80	114	78	88	220 + S
100	114	78	93	235 + S

Ordering Example:

HP.80.100. P. 1. TDL2

Part Number
Includes Series, Bore, and Stroke Length

Port Style

Mount Code
TDL2=Two Post Direct Lift with Roller Bearings and Guide Shafts

Port Location